

Operating Instructions and Parts Manual

Please read and save these instructions. Read through this owner's manual carefully before using product. Protect yourself and others by observing all safety information, warnings, and cautions. Failure to comply with instructions could result in personal injury and/or damage to product or property. Please retain instructions for future reference.

High Pressure Sandblaster Cabinet ---PSBC990

Description

- ◇ Perfectly combine traditional sandblaster cabinet with abrasive blaster tank
- ◇ Using abrasive blaster tank to get higher sanding pressure, dramatically increase cabinet type sandblaster working efficiency
- ◇ Ideally large working space, suits for various kinds of work piece
- ◇ Foot pedal valve controlling brings flexible operation for customer

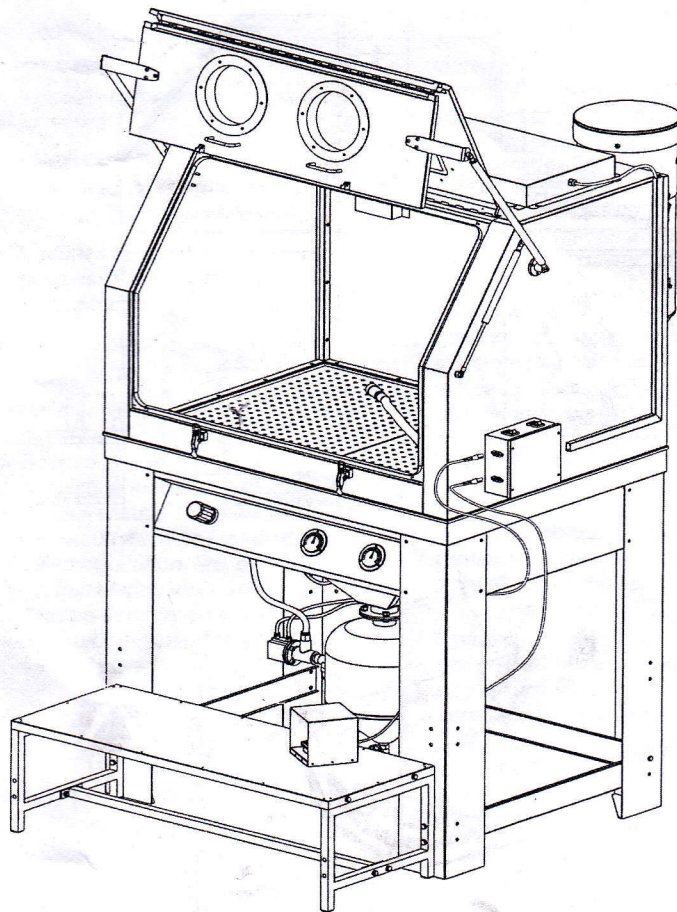

Specifications and Dimensions

Nozzle Size: ϕ 5.0 / ϕ 5.0 / ϕ 6.0 / ϕ 6.0 mm

Nozzle Material: Ceramic;

Maximum Sand Load Volume: 12 liters

Maximum Air pressure: 8kg/cm² 115PSI

Gas Flow Rate: 22-30m³/h or 13-17.5CFM

Overall Dimensions: 132*158*206cm



High Pressure Sandblaster Cabinet

Working Pressure: 2kg/cm²~8kg/cm²(30~115PSI)

Sand Hose: ϕ 250*2500mm

Sand Diameter: 25-80 Grit

Cleaning Efficiency: 400-500cm²/min @4kg/cm² air pressure with ϕ 6.0mm nozzle.

Tank Capacity: 5.4 Gallon (20.5 liters)

Tank Dimensions: ϕ 309*370;

N.W: 210kg

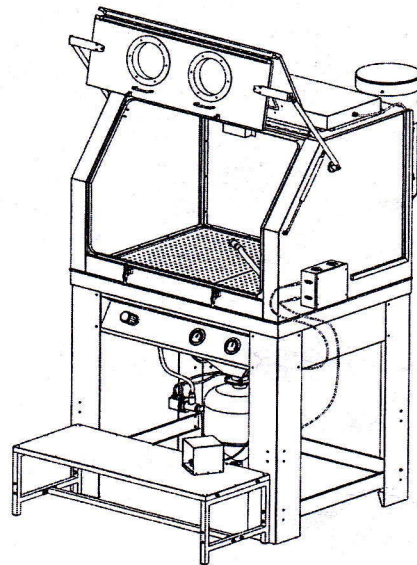
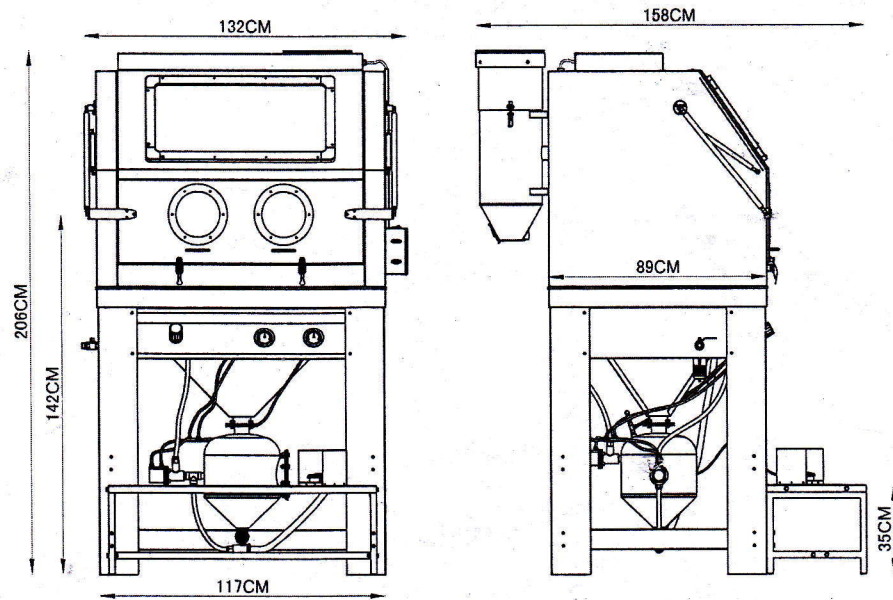

High Pressure Sandblaster Cabinet

General Safety Information

Any blast cabinet will produce a powerful flow of abrasive particles. Please avoid personal injury and property damage. Study this manual thoroughly before assembling, operating or servicing this blast cabinet.

▲ WARNING

1. *During operation, do not expose the hands or skin directly in the line of the blast nozzle.*
2. *Ensure all components seal properly after assembly.*
3. *Do not exceed the maximum operating pressure of the blasting equipment*
4. *Disconnect the cabinet from the air supply before changing accessories or attempting to install, service, relocate or perform any maintenance.*
5. *Check hoses and air lines for weak or worn condition before each use. Make sure all the connections are secure before use.*
6. *Do not point the abrasive blaster gun at anyone or objects.*
7. *Before installing the machine, consider the availability and proximity of the required power supply circuit. If an existing circuit does not meet the requirements for this machine, a new circuit must be installed. To minimize the risk of electrocution, fire, or equipment damage, installation work and electrical wiring must be done by an electrician or qualified service personnel in accordance with all applicable codes and standards.*



▲ DANGER *Chemicals, including lead includes in this product or its power cord. Wash hands after handling*



▲ DANGER *The dust can be created when you sweep, blast, cut, sand, drill or grind materials such as wood, paint, metal, concrete, cement, or other masonry. This dust often contains chemicals known to cause cancer, birth defects, or other reproductive harm. Wear protective gear.*



▲ DANGER *Fire or Explosion Hazard! DO NOT USE a sand blaster around combustible or flammable liquids, dusts, gases, oily rags, or other materials that can explode or burn quickly. Some abrasives create sparks when they hit metal. Abrasives similar to aluminum oxide may generate static electric sparks which will cause fires or explosions in an unsafe environment.*



▲ DANGER *Static electric shocks can be painful. Please wear leather or rubber soled shoes or boots and stand on the ground to avoid static electricity. A grounded wire attached to the sand blast gun will safely remove the static electricity.*

Operation Method

Connect gas and power supply---open operation door---load abrasive---put work piece in---lock the door---turn on vacuum cleaner then intake valve---adjust working pressure---step foot paddle to start.

Operating Principle

High Pressure Sandblaster Cabinet

Step on foot paddle then air outlet closed, air inlet opened, air cut valve (mushroom head) moved up to stop sand loading port and start to add pressure to tank, which could let sand be sprayed by high pressure air flow. If sand spray out too much, adjust sand valve in clockwise direction, whereas counterclockwise.

Loosen the foot paddle, the air intake closed, air outlet opened, the air in tank discharged, at the same time air cut valve (mushroom head) down by gravity, which prevent blasting gun stopping working. The sand in the hopper was dropped back into the tank by gravity. So recycling is realized.

Operation Notice

1. Before operation, check the sealing of the valve and connecting fitting and replace when necessary to ensure safe and reliable.
2. Abrasive should be filtered to prevent bring sand garbage into the nozzle or valve. The maximum sand load volume is 12 liters.
3. Do not add too much abrasive. It might make the mushroom head in the pressure tank not be sealed, which results to no sand blasting. If mushroom head withstands sand entrance, using

a small iron bar to knock mushroom head to let it down.

4. If no sand blasting, try to loose foot pedal to let sand drop back to pressure tank for recycle using.
5. Method to clean wet or waste abrasive: take sand hose down, put a woven bag, then turn on air inlet valve, adjust pressure regulating valve to 1-2kg by pressing foot paddle fitfully to make wet or waste abrasive into the Recycle Bag.
6. Discharge steam-water separator, 1-2 times daily.
7. Do periodical inspection for the mushroom head sealing ring. For any possible damage, aging, deformation, sealing leaking will affect sand blast pressure and results to air waste.
8. When you finish, clean all abrasive out in order to prevent breakdown for next operation.

Maintenance

NOTE: Disconnect power and air before the maintenance.

Cleaning: please clean the machine or parts with a soft cloth. **DO NOT** use solvents to clean.

Avoiding clog: the moist media will cause the block of nozzle. Try dislodging the media with a drill bit.

High Pressure Sandblaster Cabinet

Assembly

1

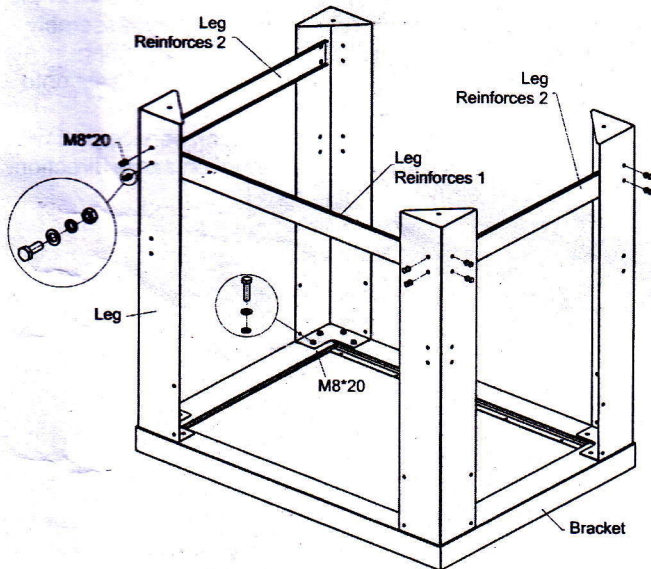

1. Fasten the four stand legs and the Leg Reinforces to the Bracket by using M8*20mm Screw, Flat Washer, Spring Washer and M8 Nut in turn.

Hardware

M8x20mm SCREW	28	
M8 Nut	12	
8 Flat Washer	28	
8 Spring Washer	28	

2

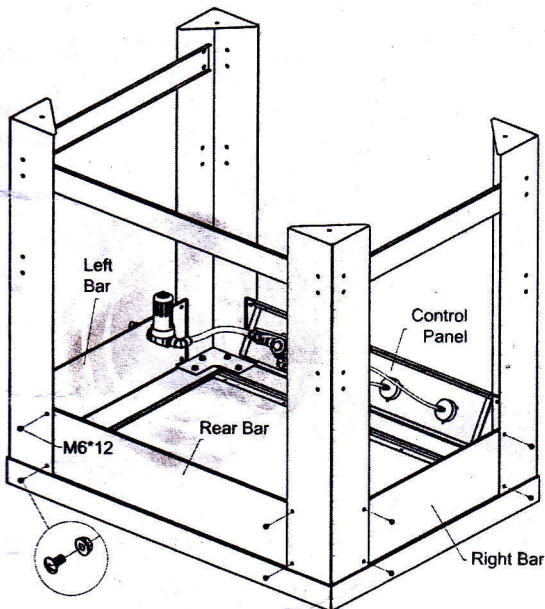

2. Assemble the Left Bar, Right Bar, Control Panel and Rear Bar by using M6*12mm Screw, Flat Washer, and M6 Nut in sequence.

Hardware

M6x12mm SCREW	16	
M6 Nut	16	
6 Flat Washer	16	
6 Spring Washer	16	

High Pressure Sandblaster Cabinet

3

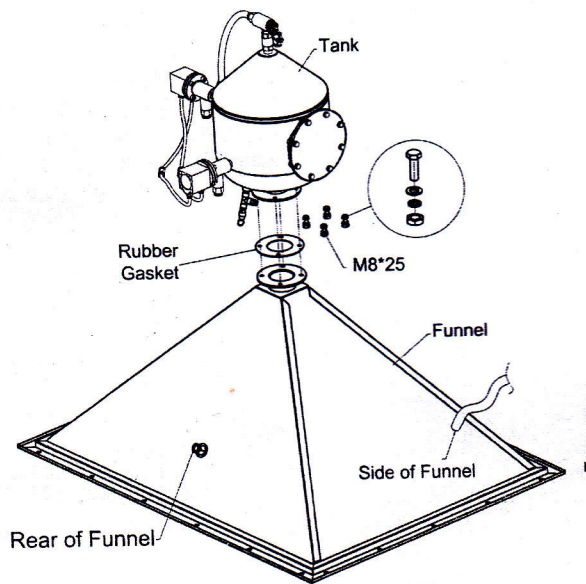

3. Place the funnel as shown in the picture. Attach the tank assembly (including flat washer, spring washer, nut) and rubber seal onto the funnel.

Note: Ensure tank service port with right side funnel on same direction.

Hardware

M8x25mm SCREW	4	
M8 Nut	4	
8 Flat Washer	4	
8 Spring Washer	4	
Rubber Gasket	1	

4

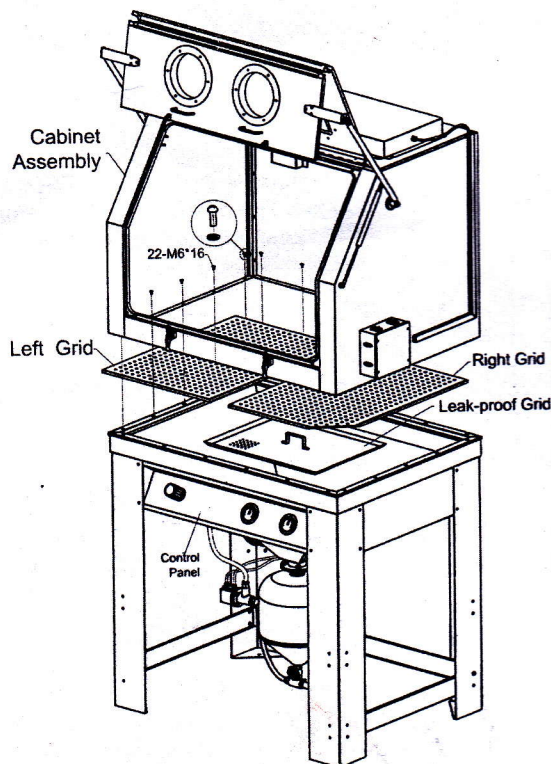

4. Upside down step 2 parts, then place the funnel and pressure tank (step 3) on. Please note that placement direction and then entered the hook plate component.

Hardware

M6x16mm SCREW	22	
6 Flat Washer	22	

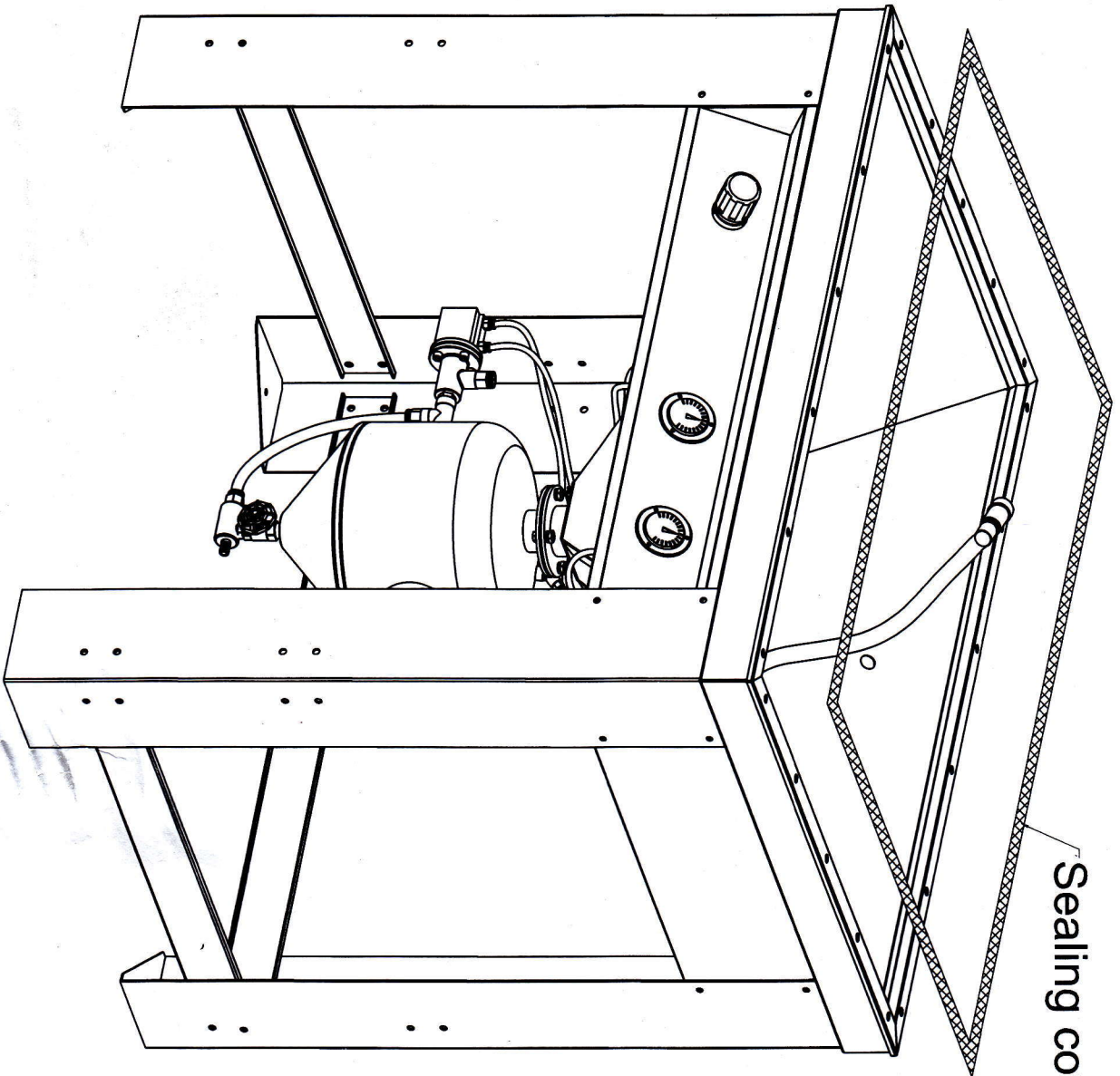

Sealing cotton δ 3



HARDWARE USED

Sealing cotton δ 3 

Stick sealing cotton on before assembling the cabinet.

High Pressure Sandblaster Cabinet

5-1

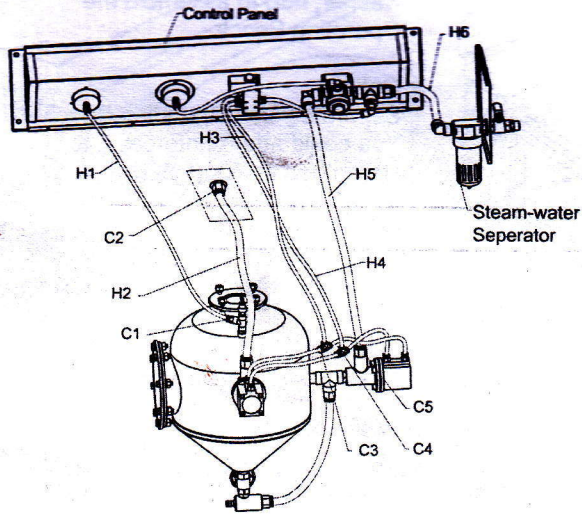

1. Insert H4 & H3 into Tee Joint (C3) on the tank (notice color response). [H3---C3]; [H4---C4]. Then insert $\phi 8$ Air Hose(H1) from pressure gauge into the top of tank quick connector [H1---C1]
2. Insert $\phi 16$ Air Hose into Air Connector[H5---C5]
3. At the right panel, connect a $\phi 16$ Air Hose(H6) with the Steam-water separator.
4. Insert air hose(H2) into the connector on back of the funnel. [H2---C2]

5-2

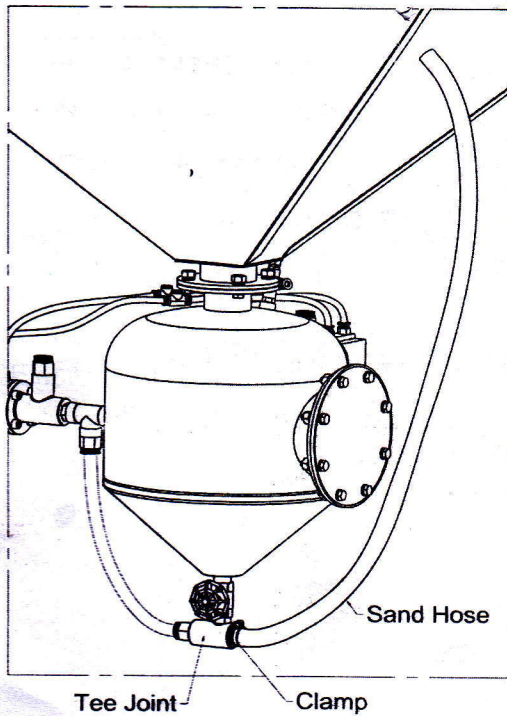

Insert Sand Hose into Tee Joint under the tank, and then use Beam Clamp to lock them as the figure showed.

High Pressure Sandblaster Cabinet

6

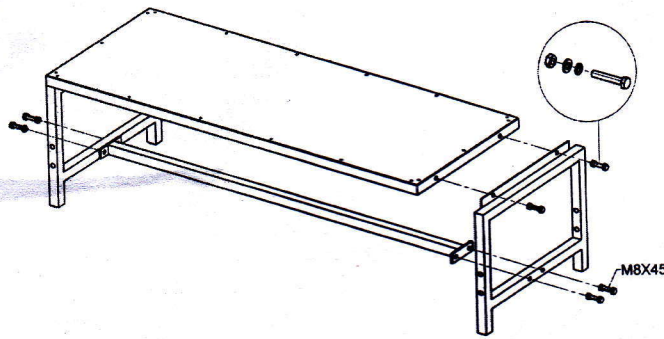

6. Using M8*45 Screw (with flat washer, nut) to assemble the Operation Bench.

Option 1

Separately use Operation Bench. You could add Reinforces 1 to strengthen as figure 6-1.

Option 2

Combined use Operation Bench. No Leg Reinforces 1 needed as figure 6-2.

M8x45mm SCREW	8	
M8 Nut	8	
8 Flat Washer	8	
8 Spring Washer	8	

6-1

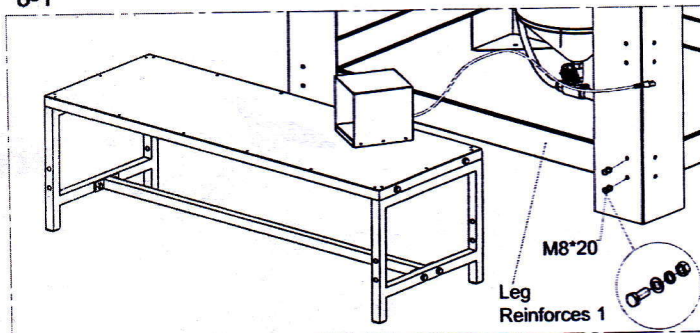

6-1

M8x20mm SCREW	4	
M8 Nut	4	
8 Flat Washer	4	
8 Spring Washer	4	

6-2

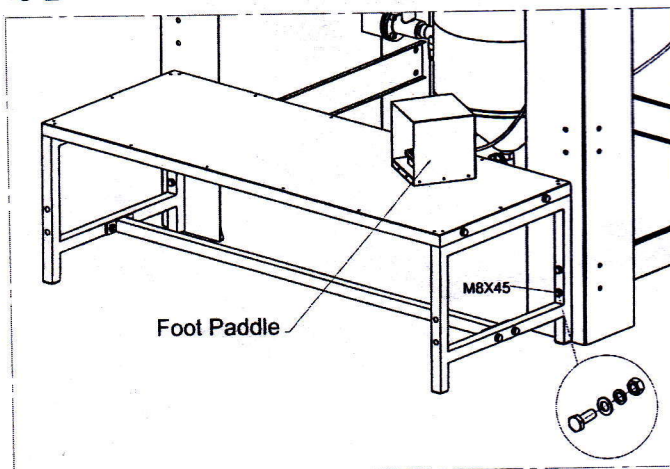

6-2



M8x45mm SCREW	4	
M8 Nut	4	
8 Flat Washer	4	
8 Spring Washer	4	

High Pressure Sandblaster Cabinet

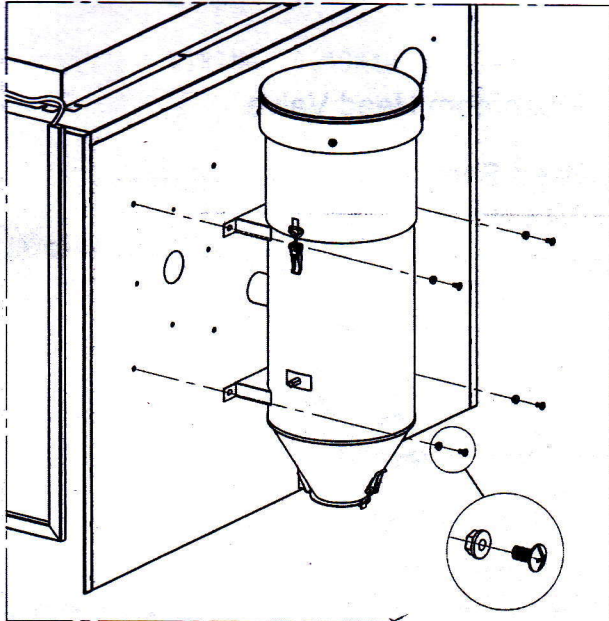
7



7-1. Using four **M6*12** Screw to fit Dust Collector to the cabinet.

- | | | |
|---------------|---|---|
| M6x12mm SCREW | 4 |  |
| M6 Nut | 4 |  |

8

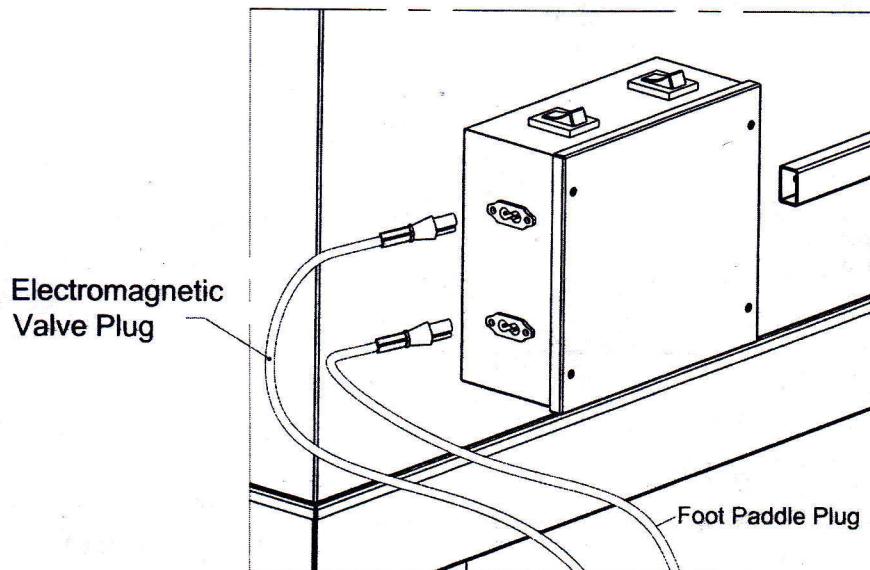

8. Plug the Electromagnetic Valve Plug and Foot Paddle Plug into the Power Supply. (Notice the label on the supply)

High Pressure Sandblaster Cabinet

Mushroom Head Replacement Graphics

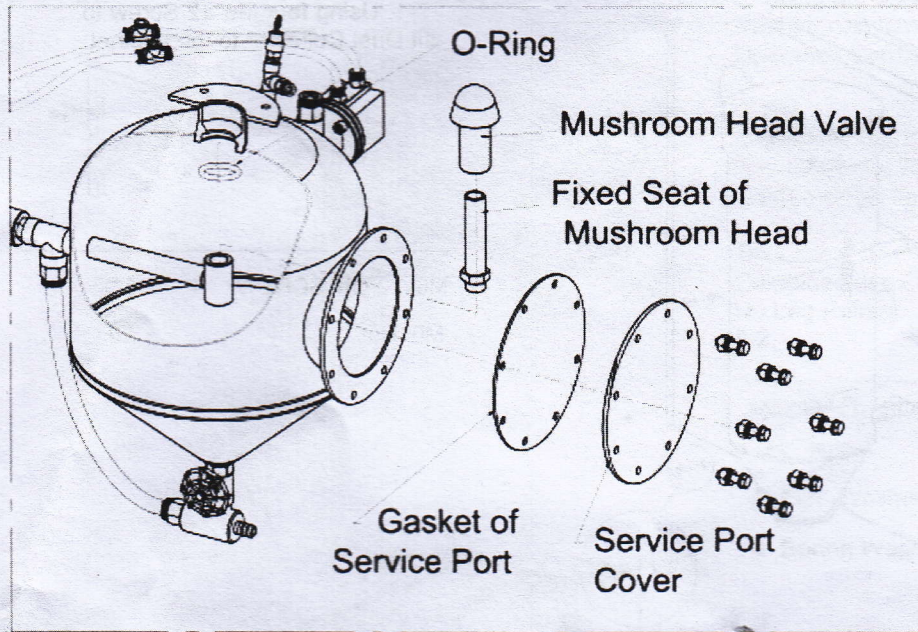

Use Recycle Bag to collect waste sand

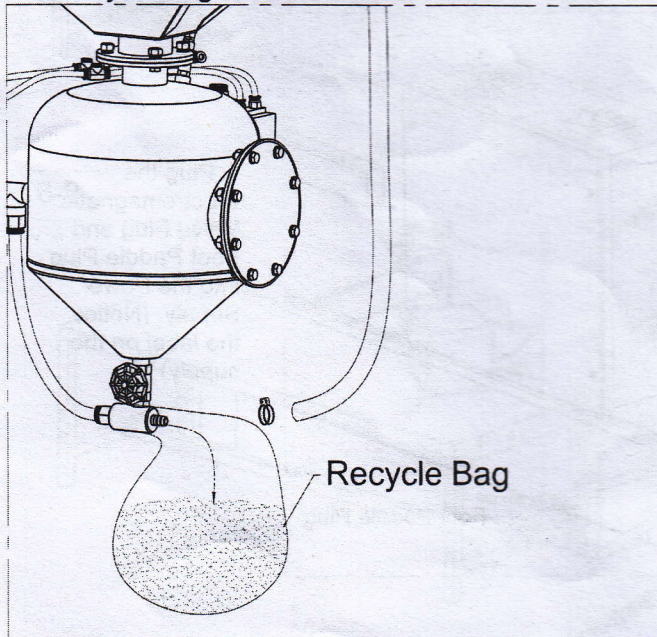

High Pressure Sandblaster Cabinet

Wiring Diagram

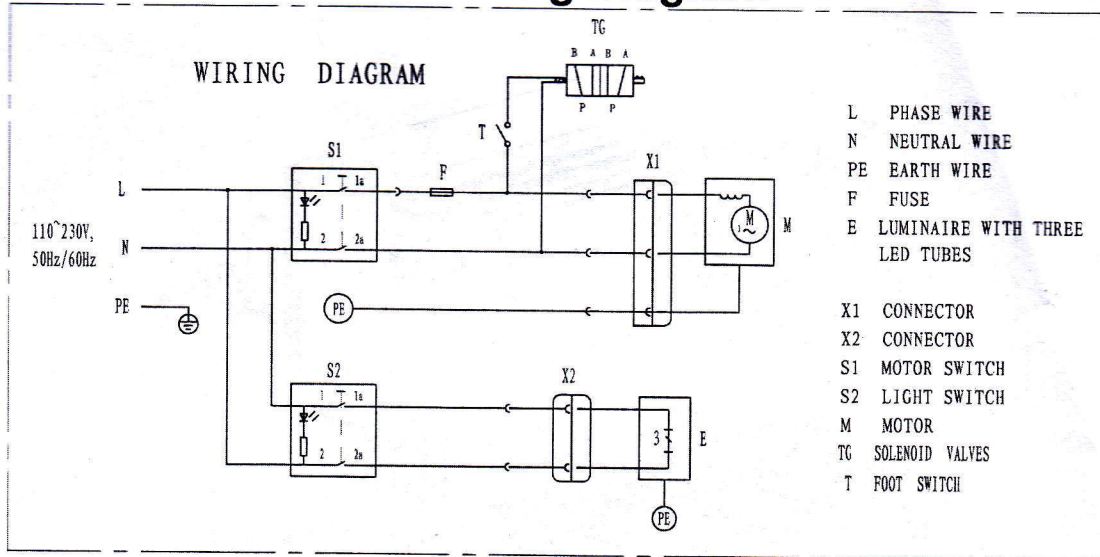

Troubleshooting

Symptom(s)	Possible Causes(s)	Possible Solution(s)
<i>Intermittent, clogging, or no media spray at the blast gun</i>	✓ No more media in the pressure tank.	1. Release foot paddle to let media flow back from funnel to pressure tank.
	✓ Suction tube has been clogged from a contaminant.	1. Close air source, open the nozzle of the blast gun for check, and take contaminant out if it has. The same as the intake-tube at the bottom of the pressure tank. 2. Make sure that the media is not worn-out, saturated with debris, or contaminated with moisture causing it to cake inside of the lines. Screen or replace media as required.
	✓ <i>Too much or too less media</i>	1. Rotating the valve under the pressure tank. If too much media, rotate by clockwise; otherwise, anticlockwise. 2. Might nozzle abrasion too much then replace a new nozzle.
<i>Mushroom head air-leaking</i>	✓ Rubber seal or mushroom head abrasion too much	1. Open maintenance cover to change rubber seal or mushroom head inside.
<i>Mushroom head cannot move up and down</i>	✓ Load too much media	1. Discharge of a part of abrasive from the tank. 2. using a small iron bar to knock mushroom head to let it down.

High Pressure Sandblaster Cabinet

Parts

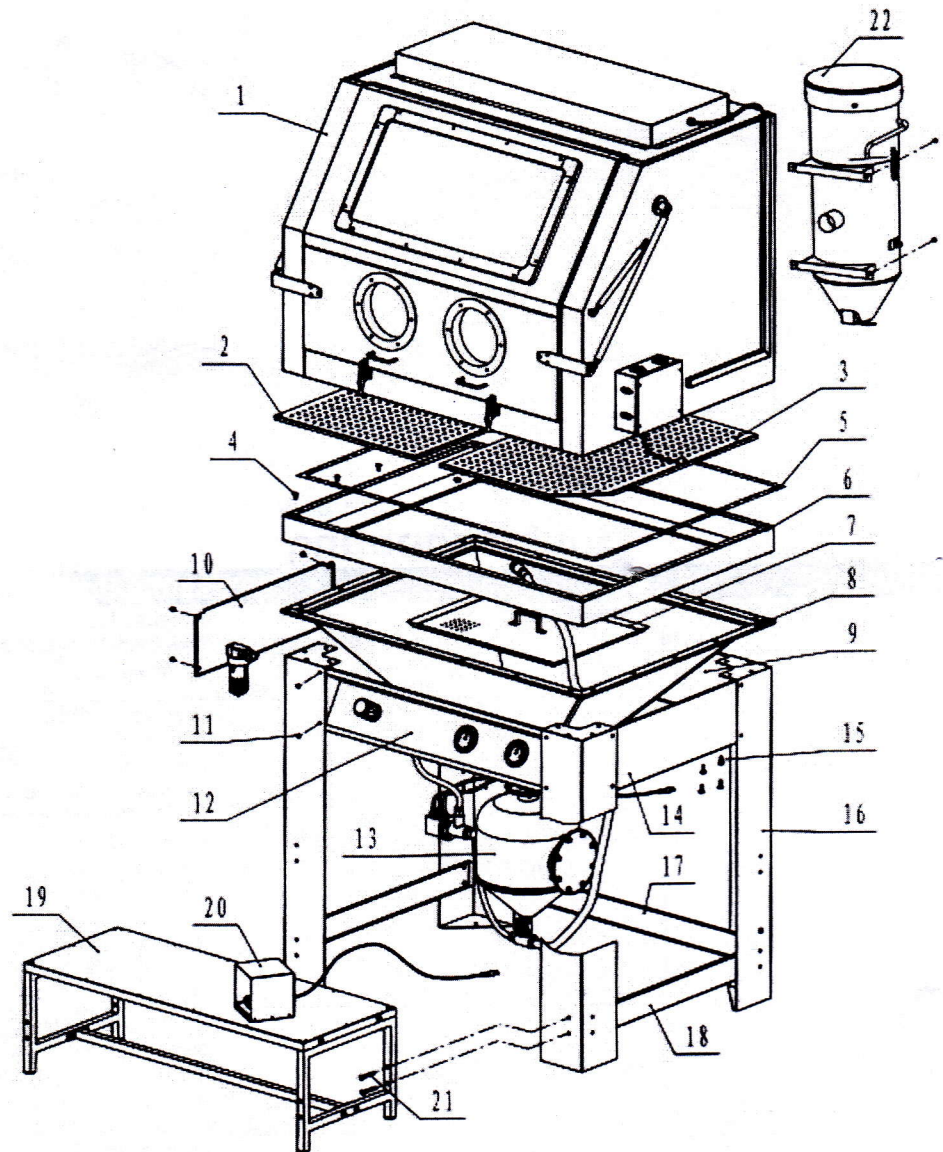

High Pressure Sandblaster Cabinet

Stand & Cabinet Base

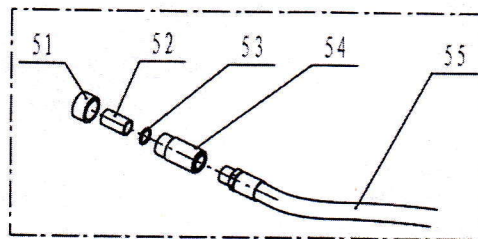
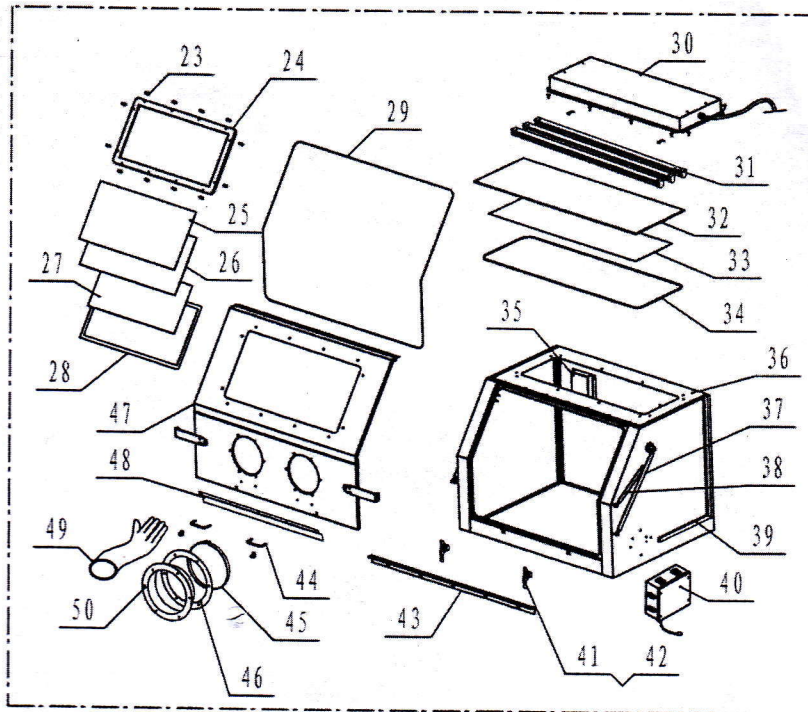

Part No.	Description	Qty.
1	Cabinet Assembly	1
2	Left Grid	1
3	Right Grid	1
4	Screw M6x16 (matched with $\phi 6 \times 16$ washers)	22
5	Foam Pad	1
6	Bracket	1
7	Leak-proof Grid	1
8	Funnel	1
9	Rear Bar	1

High Pressure Sandblaster Cabinet

10	Left Bar	1
11	Screw M6*12	16
12	Control Panel	1
13	Tank Assembly	1
14	Right Bar	1
15	Screw M8*20	28
16	Leg	4
17	Leg Reinforces 1	1
18	Leg Reinforces 2	2
19	Operation Bench	1
20	Foot Paddle	1
21	Screw M8*45	4
22	Dust Collector	1
23	Screw M6*32	12
24	Window Frame	1
25	Plastic Top	1
26	Glass	1
27	PE Film	1
28	Foam Pad of Viewing Window	1
29	Rubber Seal	1
30	Lamp Housing	1
31	LED Light	3
32	Glass of Light Window	1
33	PE Film of Light Window	1
34	Rubber Seal of Light Window	1
35	Rear Bar for Sand Blocking	2
36	Cabinet	1
37	Main Support Pole	2
38	Air Spring Support Rod	2
39	Plastic Slot Board of Wire	1
40	Switch Box	1
41	Front Door Latch	2
42	Latch Seat	2
43	Latch Board	1
44	Handle	2
45	Hoop Component	2
46	Seal Ring of Glove	2
47	Front Door	1
48	Front Bar for Sand Blocking	1

High Pressure Sandblaster Cabinet

49	Glove	1
50	Glove Seat	2
51	Nozzle Nut	1
52	Nozzle	1
53	O-Ring	1
54	Gun Body	1
55	Sand Hose	1

Tank Base

Exploded View of Left Bar

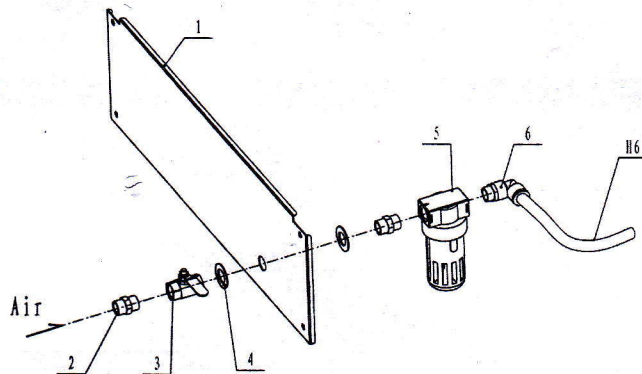

Part No.	Description	Qty.
1	Left Bar	1
2	Straight Coupling	2
3	Ball Valve	1
4	Washer	2
5	Steam-water separator	1
6	Right-angle Quick Coupling	1
H6	φ 16 Air Hose	1

High Pressure Sandblaster Cabinet

Exploded View of Control Panel

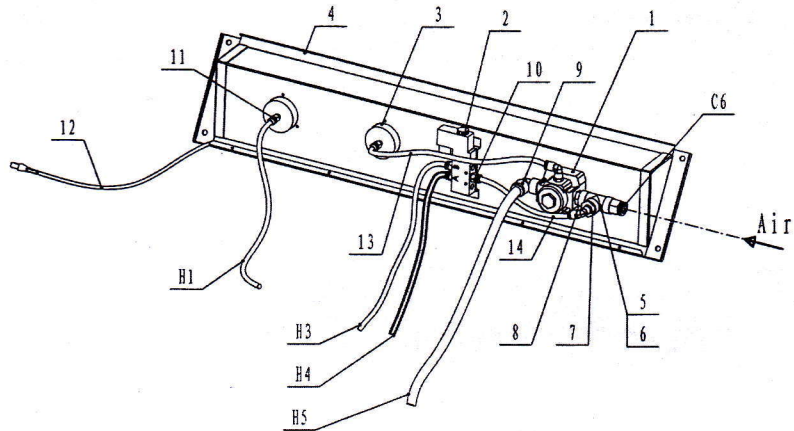

Part No.	Description	Qty.
1	Pressure Regulating Valve	1
2	Electromagnetic Valve	1
3	Pressure Gauge	2
4	Control Panel	1
5	Tee Joint	1
6	G1/2" Straight Coupling	1
7	G1/2"-G1/4" Bushing	1
8	G1/4"-8 Straight Coupling	2
9	G1/2"-16 Straight Coupling	1
10	G1/4"-8 Straight Coupling	3
11	M10*11-8 Pressure Gauge Coupling	2
12	Electromagnetic Valve Wire	1
13	φ 8 Air Pipe	1
14	φ 8 Electromagnetic Valve Air Pipe	1
H1	φ 8 Air Hose	1
H3	φ 8 Air Hose	1
H4	φ 8 Air Hose	1
H5	φ 16 Air Hose	1
C6	G1/2"-16 Straight Coupling	1

High Pressure Sandblaster Cabinet

Exploded View of Tank Assembly

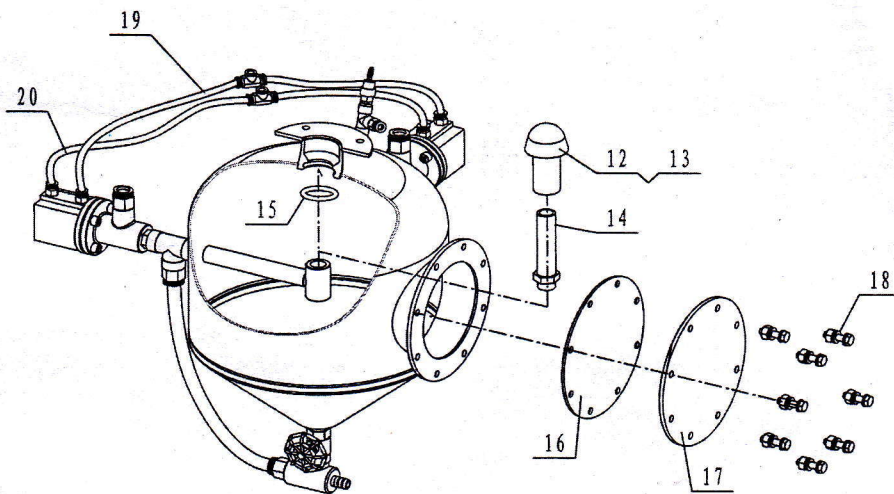

Part No.	Description	Qty.
12	Mushroom Head Fixed-tube	1
13	Mushroom Head	1
14	Inlet Welding Assembly	1
15	O-type Ring	1
16	Service Port Gasket	1
17	Service Port Cover	1
18	Screw M8*30	8
19	φ 8 Air Hose	2
20	φ 8 Air Hose	2

High Pressure Sandblaster Cabinet

Exploded View of Tank Assembly

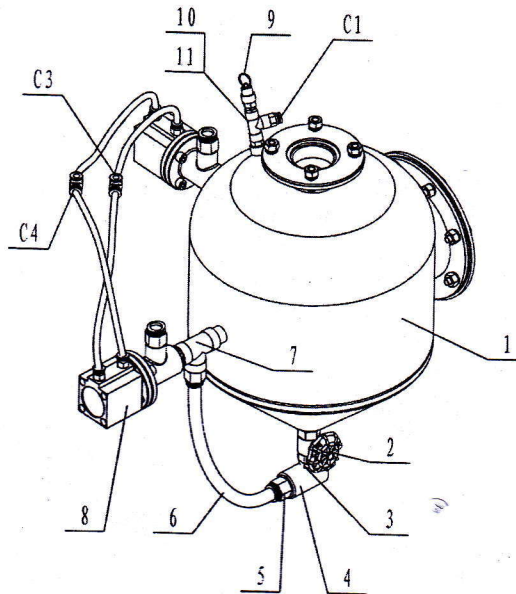

Part No.	Description	Qty.
1	Tank	1
2	Valve	1
3	G1/2" Straight Coupling	1
4	Sand Tee Joint	1
5	G1/2"-16 Straight Coupling	4
6	φ 16* φ 12 Air Hose	1
7	G1/2" Tee Joint	1
8	Cylinder Block	2
9	Safety Valve	1
10	G1/4" Tee Joint	1
11	G1/4" Straight Coupling	1
C1	Straight Coupling	1
C3	Tee Joint	1
C4	Tee Joint	1