

INSTALLATION & OPERATION MANUAL



Atlas 90HSC 9,000 lb. Capacity Two-Post Overhead Lift



Atlas Automotive Equipment
www.atlasautoequipment.com
(866) 898-2604

Revised: 12/23/2020

Read this entire manual before operation begins.

Record below the following information which is located on the serial number data plate.

Serial No. _____

Model No. _____



Date of Installation _____

———— Contents ————

General Information.	5
Product Identification	8
Packing, Transport, Storage	9
Lift Description	11
Technical Specification.	12
Safety	17
Installation	20
Operation And Use	29
Maintenance	32
Troubleshooting.	34
Parts List	35
Warranty	49

Printing Characters And Symbols

Throughout this manual, the following symbols and printing characters are used to facilitate reading:

	Indicates the operations which need proper care
	Indicates prohibited
	Indicates a possibility of danger to the operators
BOLD TYPE	Important information

	WARNING: before operating the lift and carrying out any adjustments, read carefully chapter 7 "Installation" where all operations for a properly functioning lift are shown.
---	---

General Information

This chapter contains warning instructions to operate the lift properly and prevent injury to operators or objects. This manual has been written to be used by shop technicians in charge of the lift (operator) and routine maintenance technician (maintenance operator). The operating instructions are considered to be an integral part of the machine and must remain with it for its whole useful life. Read every section of this manual carefully before operating the lift and unpacking it since it gives helpful information about:

- **Safety Of People**
- **Safety Of The Lift**
- **Safety Of Lifted Vehicles**

The company is not liable for possible problems, damage, accidents, etc. resulting from failure to follow the instructions contained in this manual. Only skilled technicians of AUTHORIZED DEALERS or SERVICE CENTERS AUTHORIZED by the manufacturer shall be allowed to carry out lifting, transport, assembling, installation, adjustment, calibration, settings, extraordinary maintenance, repairs, overhauling and dismantling of the lift.

The manufacturer is not responsible for possible damage to people, vehicles or objects if said operations are carried out by unauthorized personnel or the lift is improperly used.

Any use of the machine made by operators who are not familiar with the instructions and procedures contained herein shall be forbidden.

1.1 Manual Keeping

For a proper use of this manual, the following is recommended:

- Keep the manual near the lift, in an easily accessible place.
- Keep the manual in an area protected from the damp.
- Use this manual properly without damaging it.
- Any use of the machine made by operators who are not familiar with the instructions and procedures contained herein shall be forbidden.

This manual is an integral part of the lift: it shall be given to the new owner if and when the lift is resold.

1.2 Obligation In Case Of Malfunction



In case of machine malfunction, follow the instructions contained in the following chapters.

1.3 Cautions For The Safety Of The Operator

Operators must not be under the influence of sedatives, drugs or alcohol when operating the machine.



Before operating the lift, operators must be familiar with the position and function of all controls, as well as with the machine features shown in the chapter "Operation and use"

1.4 Warnings



Unauthorized changes and/or modifications to the machine relieve the manufacturer of any liability for possible damages to objects or people. Do not remove or make inoperative the safety devices, this would cause a violation of safety at work laws and regulations.



Any other use which differs from that provided for by the manufacturer of the machine is strictly forbidden.



The use of non genuine parts may cause damage to people or objects

1.5 Scrapping

When your machine's working life is over and it can no longer be used, it must be made inoperative by removing any connection to power sources. These units are considered as special waste material, and should be broken down into uniform parts and disposed of in compliance with current laws and regulations. If the packing are not polluting or non-biodegradable, deliver them to appropriate handling station.

Declaration Of Warranty And Limitation Of Liability

The manufacturer has paid proper attention to the preparation of this manual. However, nothing contained herein modifies or alters, in any way, the terms and conditions of manufacturer agreement by which this lift was acquired, nor increase, in any way, manufacturer's liability to the customer.

To The Reader

Every effort has been made to ensure that the information contained in this manual is correct, complete and up-to date. The manufacturer is not liable for any mistakes made when drawing up this manual and reserves the right to make any changes due the development of the product, at any time.

Product Identification

The identification data of the machine are shown in the serial plate placed on the power side column.



Use the above data both to order spare parts and when getting in touch with the manufacturer (inquiry). The removal of this label is strictly forbidden.

Machines may be updated or slightly modified from an aesthetic point of view and, as a consequence, they may present different features from these shown, this without prejudicing what has been described herein.

2.1 Warranty Certificate

The warranty is valid for a period of 12 months starting from the date of the purchase invoice.

The warranty will come immediately to an end when unauthorized modifications to the machine or parts of it are carried out.

The presence of defects in workmanship must be verified by the Manufacturer's personnel in charge.

2.2 Technical Servicing

For all servicing and maintenance operations not specified or shown in these instructions, contact your Dealer where the machine has been bought or the Manufacturer's Commercial Department.

Packing, Transport, Storage

Only skilled personnel who are familiar with the lift and this manual shall be allowed to carry out packing, lifting, handling, transport and unpacking operations.

3.1 Packing

The packing of the lift is delivered in following components:

- 1 base unit packed in a steel frame, wrapped up in non-scratch material, including all the accessories.
- 1 power unit packed in a carton box.

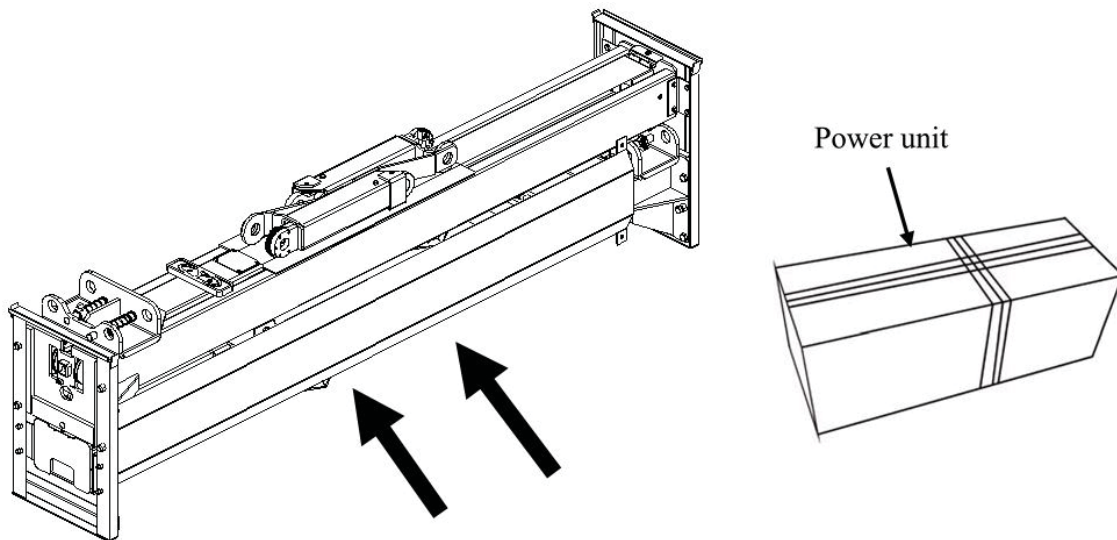

Figure 1 - Packages

3.2 Lifting And Handling

When loading/unloading or transporting the equipment to the site, be sure to use suitable loading (e.g. cranes, trucks) and hoisting means. Be sure also to hoist and transport the components securely so that they cannot drop, taking into consideration the package's size, weight and center of gravity and it's fragile parts.

3.3 Storage And Stacking Of Packages

Packages must be stored in a covered place, out of direct sunlight and in low humidity, at a temperature between 14°F and 104°F.

3.4 Delivery And Check Of Packages

When the lift is delivered, check for possible damages due to transport and storage; verify that what is specified in the manufacturer's confirmation of order is included. In case of damage in transit, the customer must immediately inform the carrier of the problem.

Packages must be opened paying attention not to cause damage to people (keep a safe distance when opening straps) and parts of the lift (be careful the objects do not drop from the package when opening).

Lift Description

The lift is suitable for lifting motor vehicles having maximum weight as described in the nameplate on the power side column of the lift. All mechanical parts such as columns, carriages and lift arms have been built in steel plate to make the frame stiff and strong while keeping a low weight. The electro hydraulic operation is described in detail in chapter 8.

This chapter describes the lift's principal elements, allowing the user to be familiar with the machine. As shown in figure 2, the lift is composed of two columns: power-side column (1) and off-side column (2), each equipped with a carriage (3) and a pair of lifting arms (4) with the adapter (5) anchored to the ground by means of base plates. The overhead beam (6) is equipped with the anti-crush safety bar and an overhead cut-off switch for protection of the vehicle roof. Raising motion is carried out by pushing the lifting button on a power unit (7) which delivers the hydraulic fluid to cylinders inside the columns to act on the chain system to raise the lift. Lowering the vehicle by pushing down the lowering handle on the power unit while holding down the safety lock handle (8). The synchronization is controlled by the equalizer cables. The arm safety can be engaged automatically when the lift is raised.

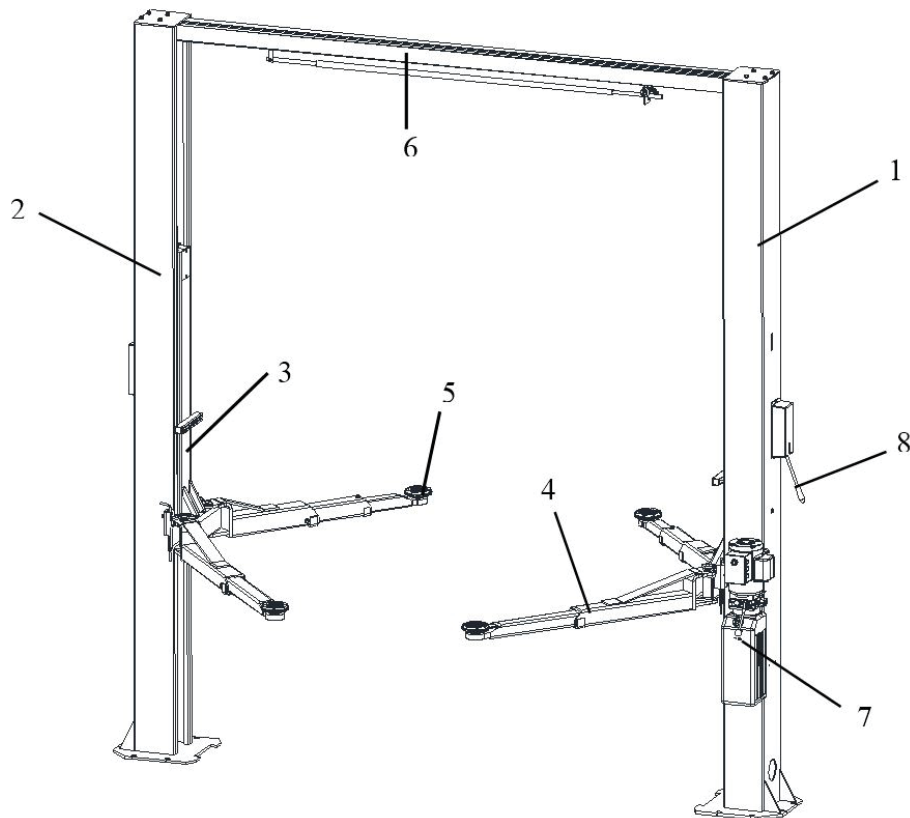

Figure 2 – Lift

Technical Specification

5.1 Size And Main Features

CAPACITY	9000 lbs
Max. stroke	37" (940mm)
Max. lifting height with no pad extension	76 3/4" (1950mm)
Min. adapter height	3 7/8" (98mm)
Overall height	141 3/4" (3600mm)
Overall width	133 1/2" (3390mm)
Lifting time	50 S
Lowering time	30 S
Noise level	75 dB(A)/1m
Working temperature	14°F and 104°F (-10 °C - 40 °C)
Average weight of package	1477 lbs

5.2 Electric Motor

Voltage	220V/60Hz/1Ph
Power	2.2kw
N° Poles	2
Speed	3450 rpm
Motor enclosure type	B14
Insulation class	IP 54

Motor connection must be carried out referring to the attached wiring diagrams the figure 6. The motor direction of rotation is shown in the label placed on the motor.

Before use of the lift, make sure to check if the motor specification shown in the nameplate of the motor conforms to the local electric supply. If there is over 10% fluctuation on the electrical power supply, it is suggested to use the voltage stabilizer to protect the electrical components and system from overloading.

5.3 Pump

Type	Gear
Flow rate	2.1 cm ³ /g
Continuous working pressure	2600 PSI
Peak pressure	2900 PSI

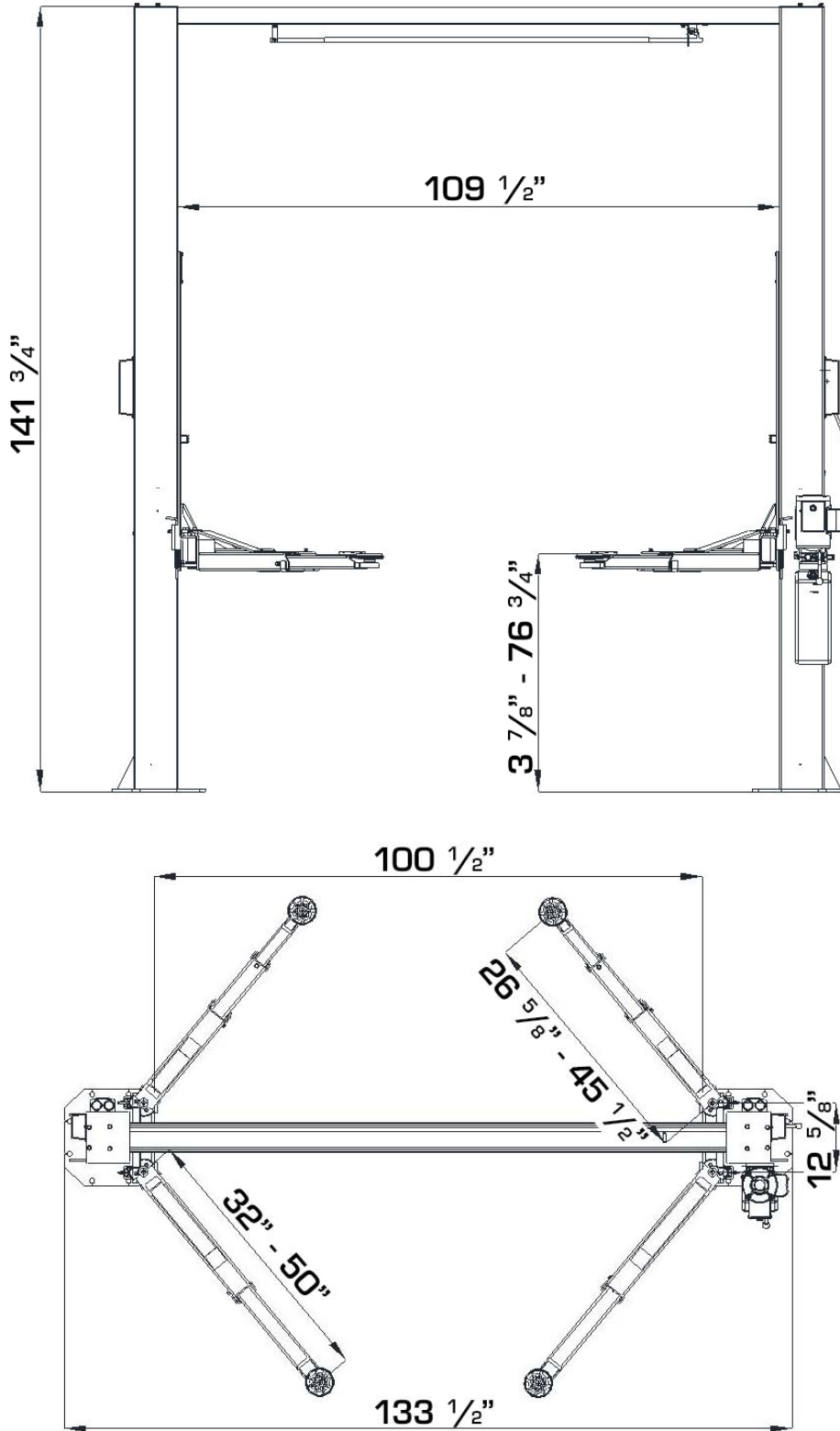

Figure 3 – Layout

5.4 Hydraulic Power Unit

The power unit is equipped with

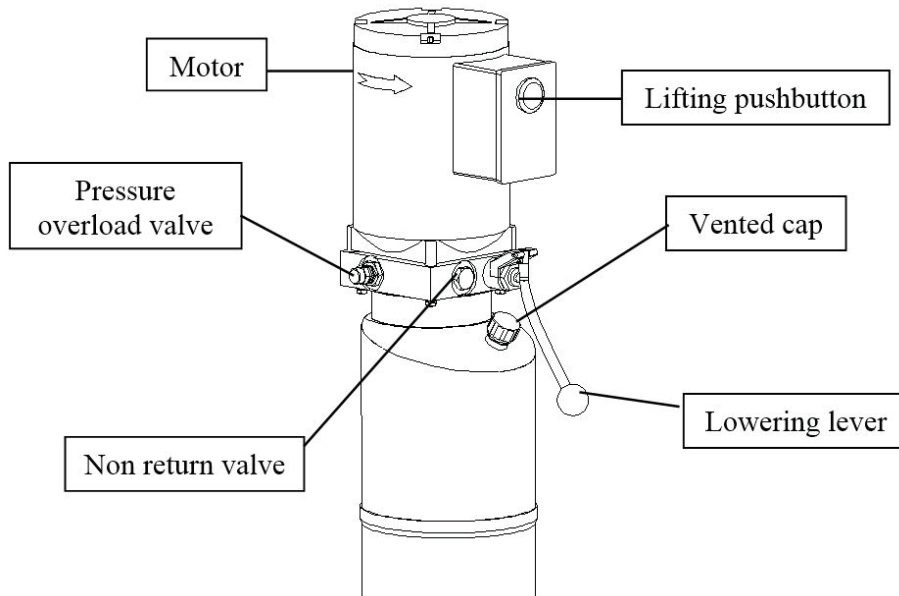

Figure 4 – Hydraulic Power Unit

5.5 Oil

Use wear proof oil for hydraulic drive, in conformity with *ISO 6743/4* rules (HM class). The oil with features similar to those shown in the table is recommended.

Test standards	Features	Value
ASTM D 1298	Density 20°C	0.8 kg/l
ASTM D 445	Viscosity 40°C	32 cSt
ASTM D 445	Viscosity 100°C	5.43 cSt
ASTM D 2270	Viscosity index	104 N°
ASTM D 97	Pour point	~ 30 °C
ASTM D 92	Flash point	215 °C
ASTM D 644	Neutralization number	0.5 mg KOH/g



Change hydraulic oil at 1 year intervals

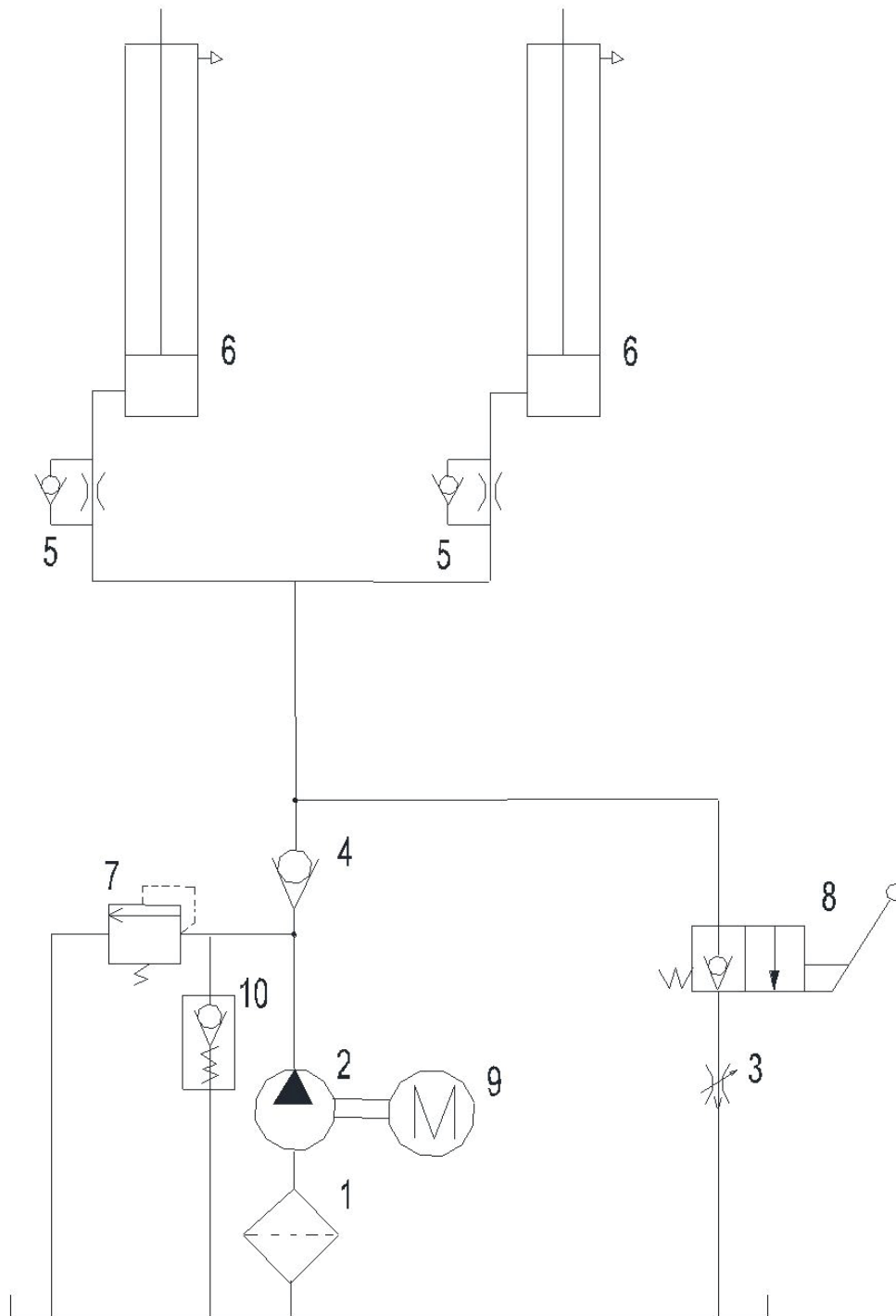

Figure 5 - Hydraulic Plan

1	Oil filter	6	Hydraulic cylinder
2	Gear pump	7	Pressure overload valve
3	Flow restrictor	8	Manual lowering valve
4	Non return valve	9	Motor
5	Lowering speed control valve	10	Startup valve

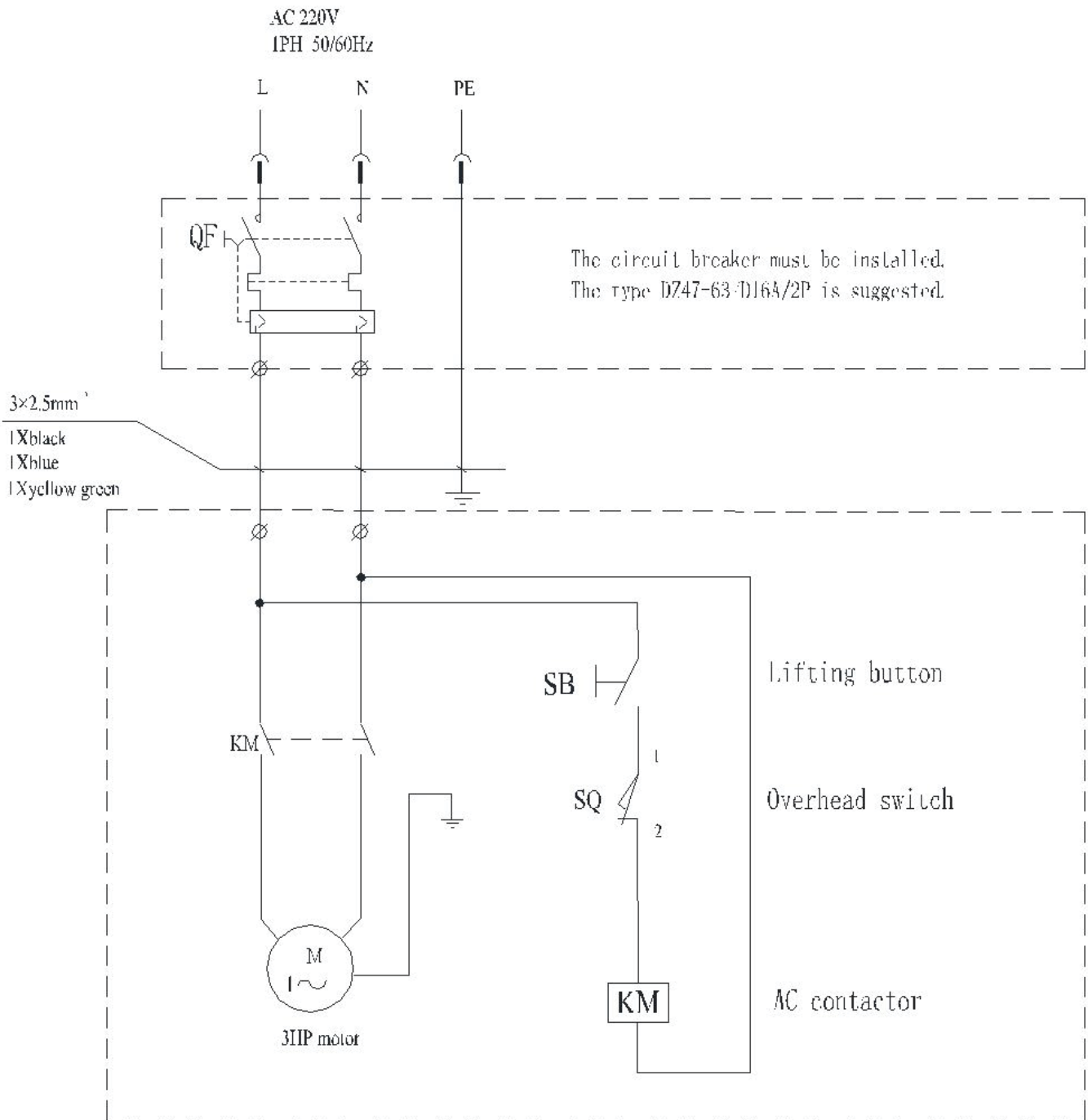



Figure 6 – Electrical Diagram (220V/230V/50Hz/60Hz/1Ph)

Safety

Read this chapter carefully and completely because it contains important information for the safety of the operator and the person in charge of maintenance.

	<p>The lift has been designed and built for lifting vehicles and making them stand above level in a closed area. Any other use is forbidden.</p> <p>The manufacturer is not liable for possible damages to people, vehicles or objects resulting from an improper or unauthorized use of the lift.</p>
---	--

For operator and people safety, a square space for a safety area at least 1m free away from the lift must be vacated during lifting and lowering. The lift must be operated only from the operator's control site in this safety area.

Operator's presence under the vehicle, during working, is only admitted when the vehicle is lifted and the safety lock is engaged.

	<p>Never use the lift when safety devices are off-line. People, the lift and the vehicles lifted can be seriously damaged if these instructions are not followed.</p>
---	--

6.1 General Warnings

The operator and the person in charge of maintenance must follow accident-prevention laws and rules in force in the country where the lift is installed.

They also must carry out the following:

- Neither remove nor disconnect hydraulic, electric or other safety devices;
- Carefully follow the safety indications applied on the machine and included in the manual;
- Observe the safety area during lifting;

- Be sure the motor of the vehicle is off, the gear engaged and the parking brake put on;
- Be sure only authorized vehicles are lifted without exceeding the maximum lifting capacity;
- Verify that no one is on the arms during lifting or standing.

6.2 Safety Device

To avoid overloading and possible breaking, the following safety devices have been used:

- A pressure overload valve built inside the hydraulic power unit to prevent excessive weight.

	<p>The pressure overload valve has been preset by the manufacturer to a proper pressure. DO NOT try to adjust it to overrun the rated lifting capacity.</p>
---	--

- Mechanical safeties built in each carriage with automatic engagement for lifting safety.

	<p>It is strictly forbidden to modify any safety device. Always ensure the safety device for proper operation during the service.</p>
---	--

6.3 Safety Signs

All safety warning signs (ref. figure 7) displayed on the lift are with the purpose to draw the operator's attention to dangerous or unsafe situations. The labels must be kept clean and they have to be replaced if detached or damaged. Read the meaning of the labels carefully and memorize it.

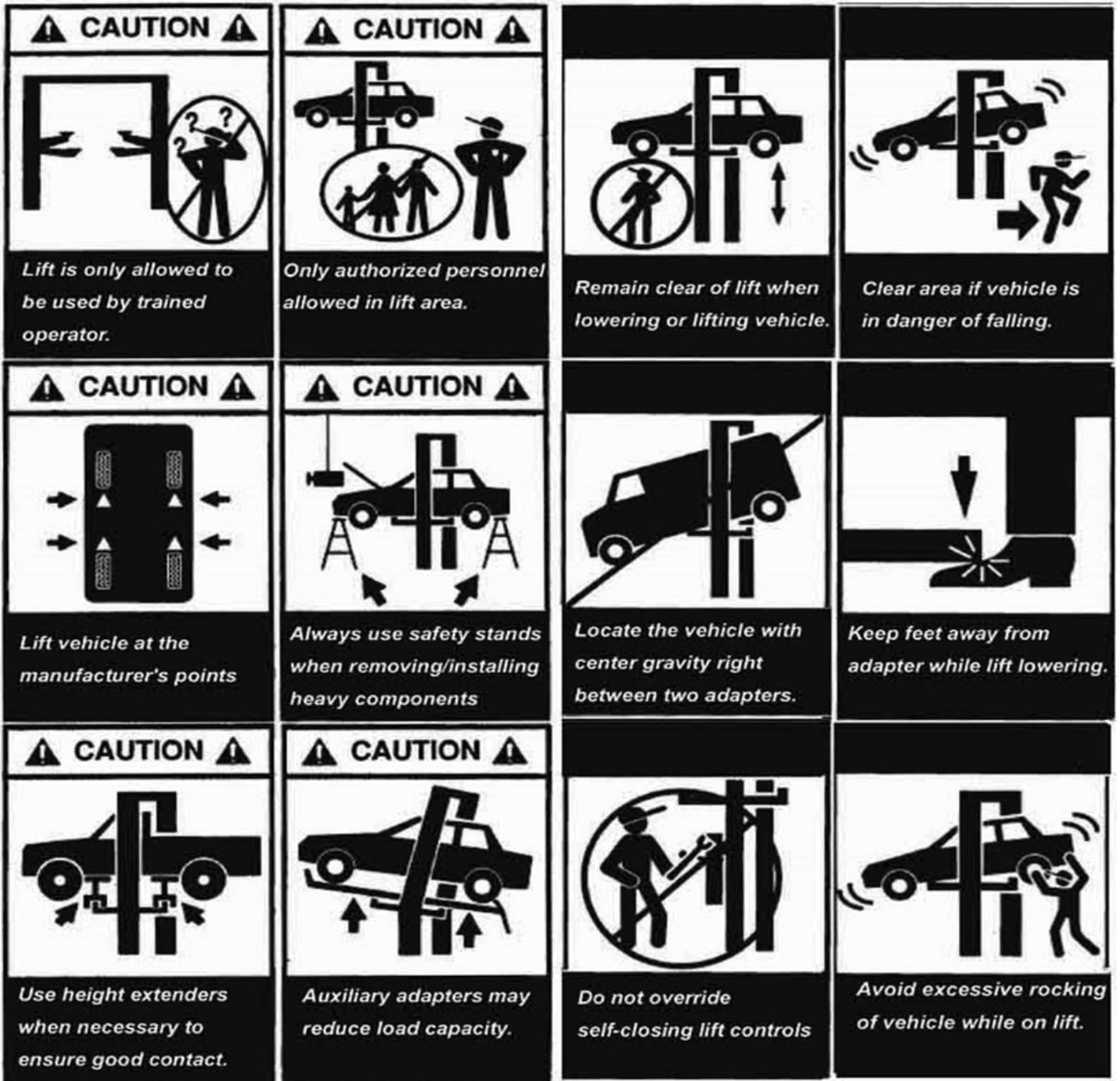

Figure 7 – Safety Signs

Installation



Only skilled technicians, appointed by the manufacturer, or by authorized dealers, must be allowed to carry out installation. Serious damage to people and to the lift can be caused if installations are made by unskilled personnel.

Always refer to the exploded views attached during installation.

7.1 Tool Required

Rotary Hammer Drill D.20	Hex-Key/Allen Wrench Set
Masonry Bit	Crow Bar For Shim Installation
Hammer	Chalk Line
Level	Medium Cross Screwdriver
Open-End Wrench Set	Medium Flat Screwdriver
Medium Crescent Wrench	Tape Measure

7.2 Checking For Room Suitability

The lift has been designed to be used in covered and sheltered places free of overhead obstructions.

The place of installation must not be next to washing areas, painting workbenches, solvent or varnish deposits. The installation near to rooms, where a dangerous situation of explosion can occur, is strictly forbidden. The relevant standards of the local Health and Safety at Work regulations, for instance, with respect to minimum distance to wall or other equipment, escapes and the like, must be observed.

7.3 Lighting

Lighting must be carried out according to the effective regulations of the place of installation. All areas next to the lift must be well and uniformly lit.

7.4 Floor Requirement

The lift MUST be installed on 3000 PSI concrete with the minimum 4" thickness and an extension of at least 3 feet from anchoring points. New concrete must be adequately cured by at least 20 days minimum.



Specifications of concrete must be adhered to. Failure to do so could cause lift failure resulting in personal injury or death.



A level floor is suggested for proper installation. Small differences in floor slope may be compensated for by proper shimming. Any major slope change will affect the level lifting performance. If a floor is of questionable slope considering to pour the new concrete slab.

7.5 Site Layout

- Now locate the lift according to the floor plan the figure 8, use a carpenter's chalk line to layout a grid for the column locations.
- After the column locations are properly marked, use a chalk or crayon to make an outline of the columns on the floor at each location using the column base plates as a template.
- Double check all dimensions and make sure that the bases of each column are square and aligned with the chalk line.

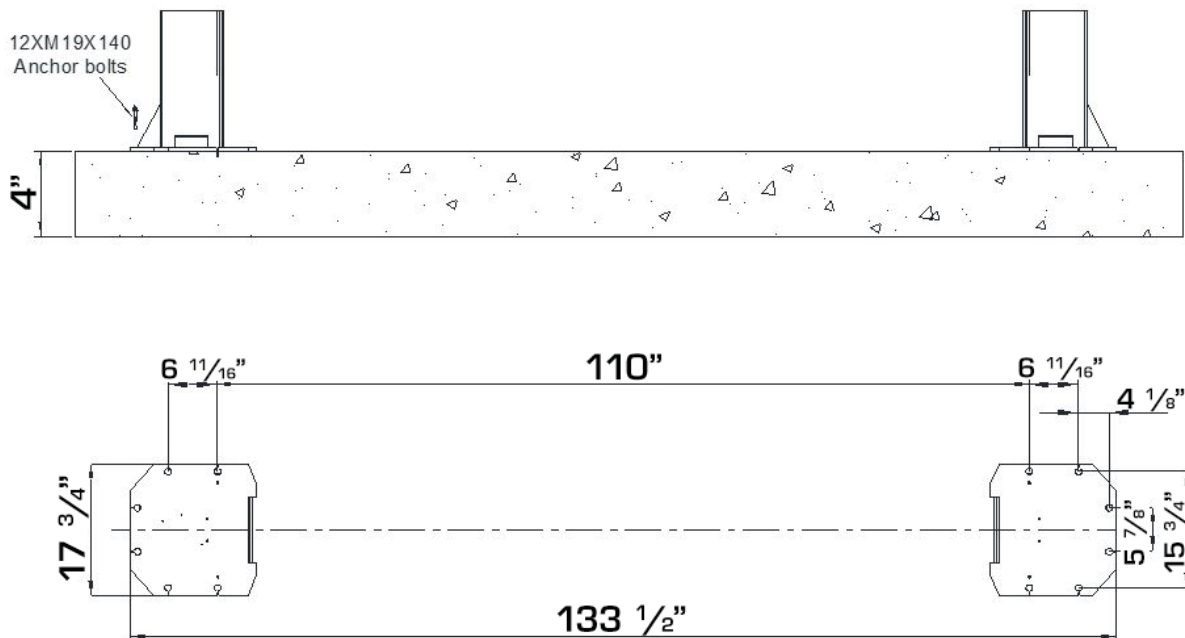
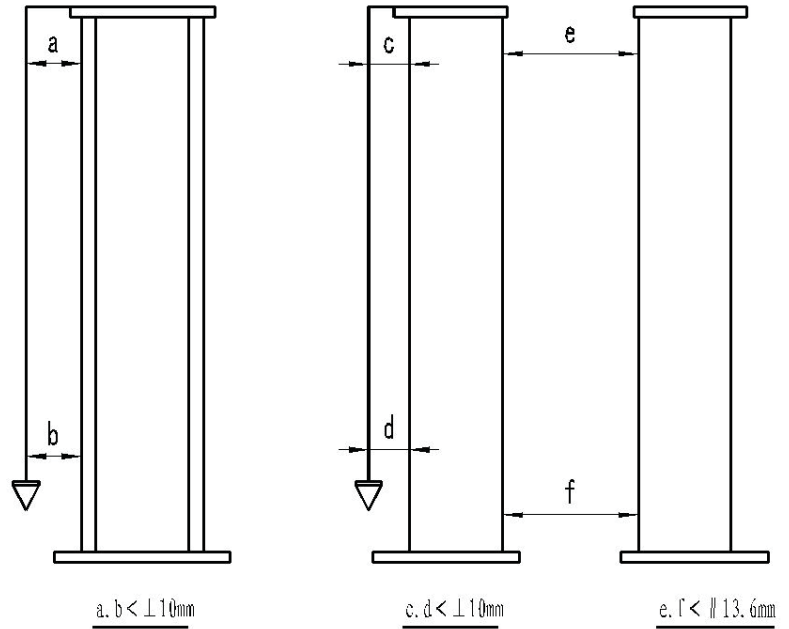

Figure 8 – Floor Plan

7.6 Anchoring Columns

- Use the base plate on the column as a guide, drill each hole in the concrete approximately 4" deep with the rotary hammer drill D.20. To assure full holding power, do not ream the hole or allow drill to wobble;
- After drilling, remove dust thoroughly from each hole using compressed air and/or wire brush. Make certain that the column remains aligned with the chalk line during this process;



- Assemble the washers and nuts on the anchors then tap into each hole with a hammer until the washer rests against the base plate. Be sure that if shimming is required that enough threads are left exposed;
- If shimming is required, insert the shims as necessary under the base plate so that when the anchor bolts are tightened, the columns will be plumb;
- With the shims and anchor bolts in place, tighten by securing the nut to the base. DO NOT use an impact wrench for this procedure;
- Anchor another column as outlined in above steps;
- Check to make sure that the columns for square-ness and plumb are as shown in the figure 9.



The requirements for column's square-ness and plumb must be adhered to. Failure to do so could cause lift failure resulting in personal injury or death.

7.7 Installation Of The Overhead Beam

- Use a lifting device to raise the assembled beam into position on top of the columns;
- Fix the beam to columns using the supplied screws, tighter the screws. Make sure to position the top micro-switch support adjacent the power-side column as shown in the figure 10;
- Place the anti-crash safety bar on the supports;
- Fix the micro-switch on the support.

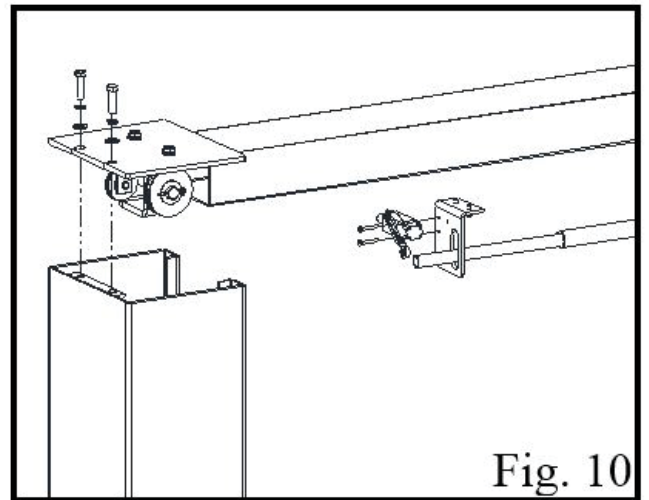

7.8 Routing The Equalizer Cables



The equalizer cables should be checked weekly for equal tension. Failure to do this will cause uneven lifting. The cables should always be adjusted so that they are equal tension when resting on the safety locks.

- Use an appropriate lifting equipment to raise the carriage to the first latch position. Be sure the carriage is engaged securely before attempting to route the equalizer cables. Carriages must be equal height from the floor before proceeding;
- With the carriages in equal height, fit the cable end-ups through the small holes of the carriages (ref. fig. 11):
- Route the equalizer cables referring to the diagram (fig. 11). Make sure the cables in the place on the pulleys. Make sure the cables routed properly;
- After the equalizer cables have been routed, adjust the nuts M12 to make each cable in equal tension;

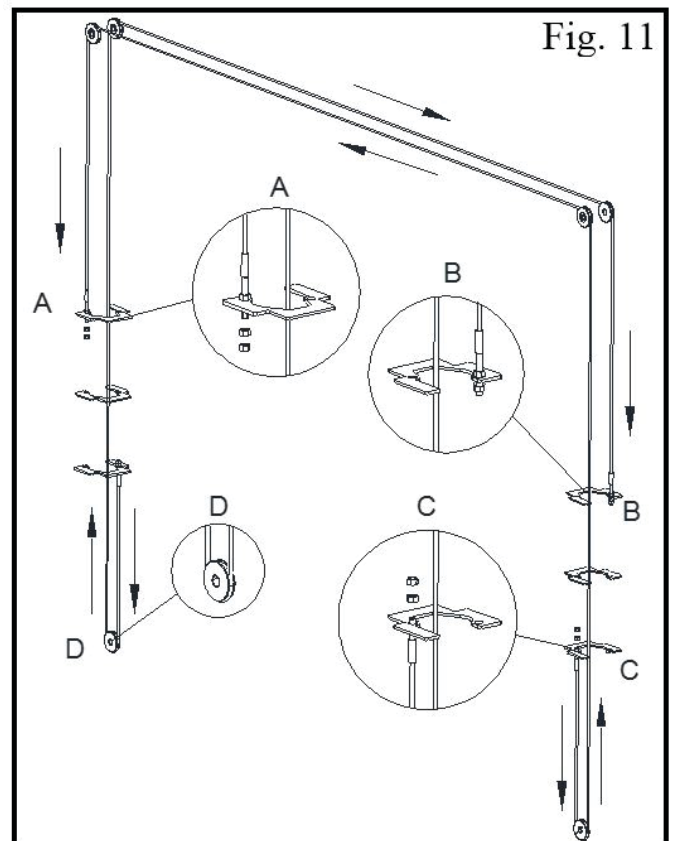

7.9 Routing The Safety Release Cable



Assemble the safety cable from offside safety assembly, pay attention to the connecting direction of safety cable.

- Install the safety rack to the off-side column (ref. fig. 12);
- Feed the end of cable through the slot of safety rack;
- Continue routing the cable to the power-side column referring to the diagram (fig. 13). Make sure the cables routed on the guides mounted previously on the columns.

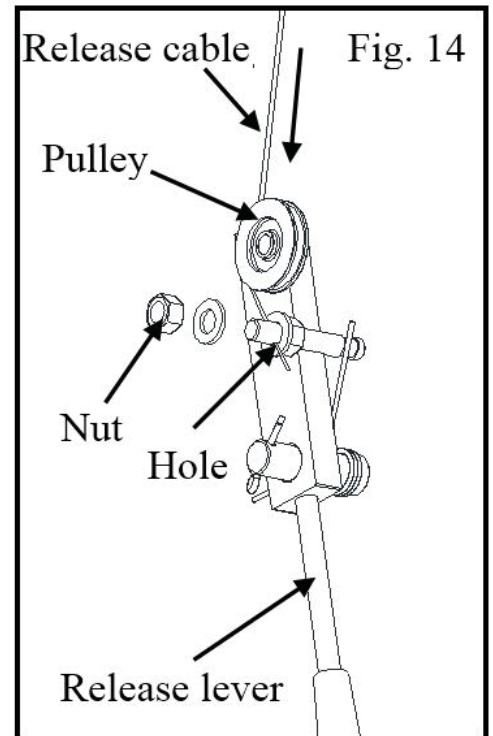
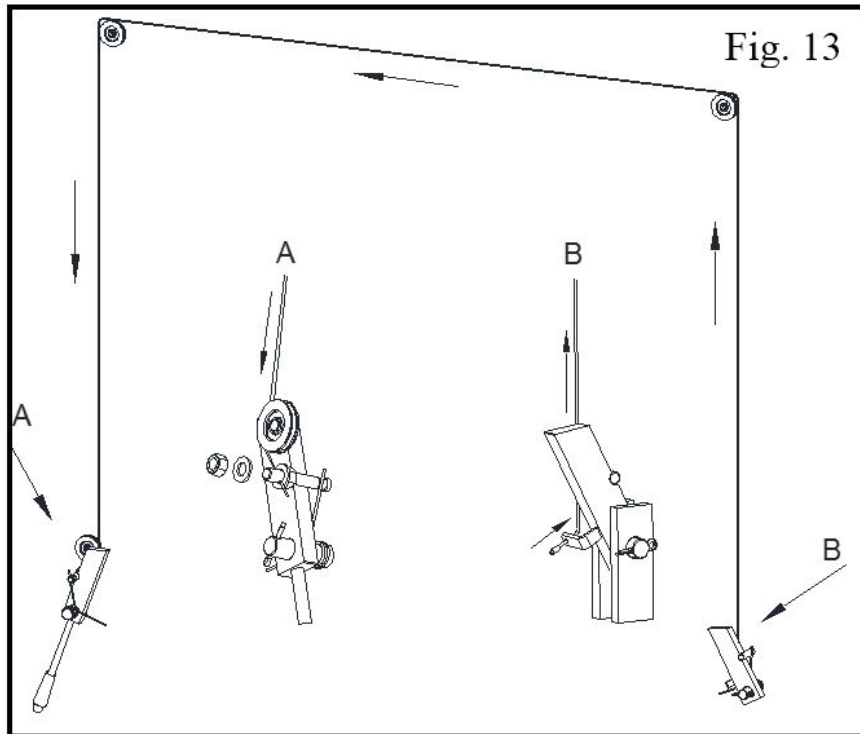
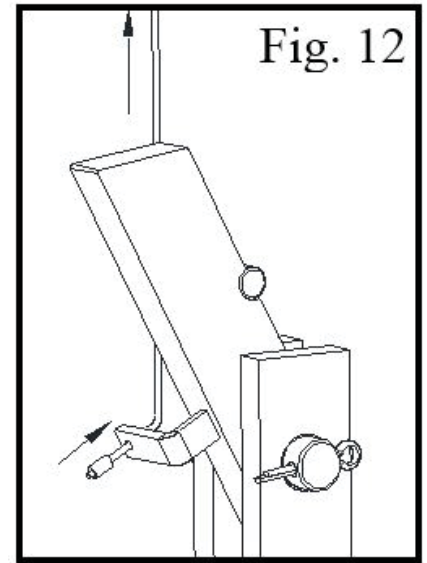

- Install the cable pulley and the retaining rings in upper slot of the power-side column (ref. fig. 14);
- Feed another end of the cable through the upper slot and make sure cable is routed at the lower of the pulley and inside the column (ref. fig. 14);
- Slip the end of the cable through the hole of safety hook; tighten the M12 nut (ref. fig. 14).

7.10 Installation Of Power Unit

- Attach the power unit onto the bracket on the power side column;
- Secure it using nuts M10X20, the locking washers D.10 and washers D. 10.

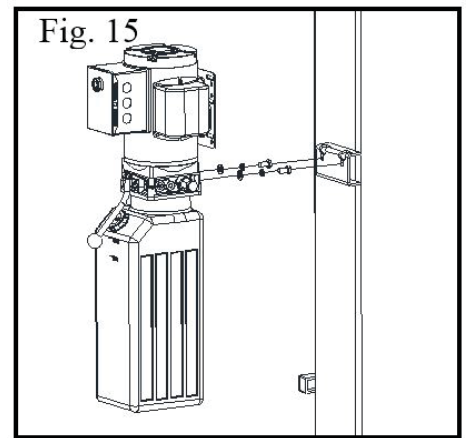

7.11 Connection Of Hydraulic Hoses



When routing the hydraulic hose, make sure that the hose is clear of any moving part. Make sure to keep the hoses clean from dust.

Make sure not to over-tighten the hose fittings so as to result in oil leakage.

- Clean the hoses and fittings;
- Inspect all threads for damage and make sure that all hose fittings are in good condition;
- Route the hoses referring the figure 16;
- Tighten the hose fittings thoroughly.

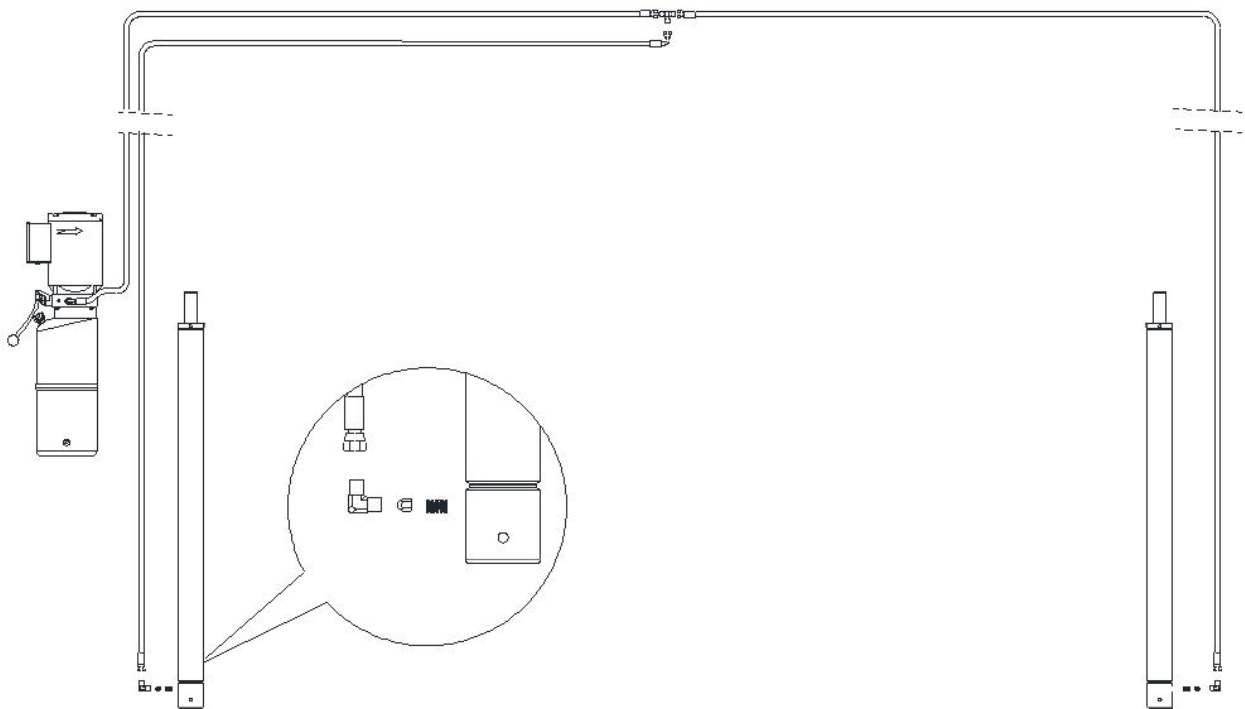



Figure 16 – Hydraulic Line Connection

7.11 Make The Electrical Connection

	<p>The hookup work must be carried out by a qualified electrician.</p> <p>Make sure that the power supply is right.</p> <p>Make sure the connection of the phases is right. Improper electrical hook-up can damage motor and will not be covered under warranty.</p> <p>Make sure the lift is ground well.</p>
---	--

	<p>It is strictly forbidden to use 60Hz motor on 50Hz power supply. Never operate the motor on the power less than 208V. Motor damage may occur.</p>
---	--

- Make the electric hookup to the hydraulic power unit referring to the wiring diagram (fig. 6);
- Make sure to install a proper circuit breaker on the circuit (DZ47-63/D16A/2P is suggested for single phase 208-240V) and (DZ47-63/D10A/3P is suggested for triple phase 380-400V);
- Make sure the lift is grounded well.

7.12 Oil Filling And Bleeding

	<p>DO NOT run power unit without oil. Damage to pump can occur. If motor gets hot or sounds peculiar, stop immediately and recheck the electric connection.</p>
---	--

	<p>If the vented cap is lost or broken, order the replacement. The oil tank must be vented well.</p>
---	---

- Use the hydraulic fluid recommended in the chapter 5.5;
- Remove the vented cap on the oil tank and pour oil in the tank about 10 liters;
- Cycle the lift up and down several times to insure latches click together and all air is removed from the system;
- To lower the lift, both latch releases must be manually released. Latches will automatically reset once the lift ascends approximately 16" from base;
- If latches click out of synchronization, tighten the cable on the one that clicks later;
- Fill the more fluid if necessary till the tank is full.

7.13 Installation Of Lifting Arms

- Grease the carriage tube and all pivot pins prior to installation.
- Install the lifting arms on the carriages using the included pins as shown in the figure 17.
- Check for proper engagement of the arm safety. Adjust it if necessary (ref. Fig. 18)

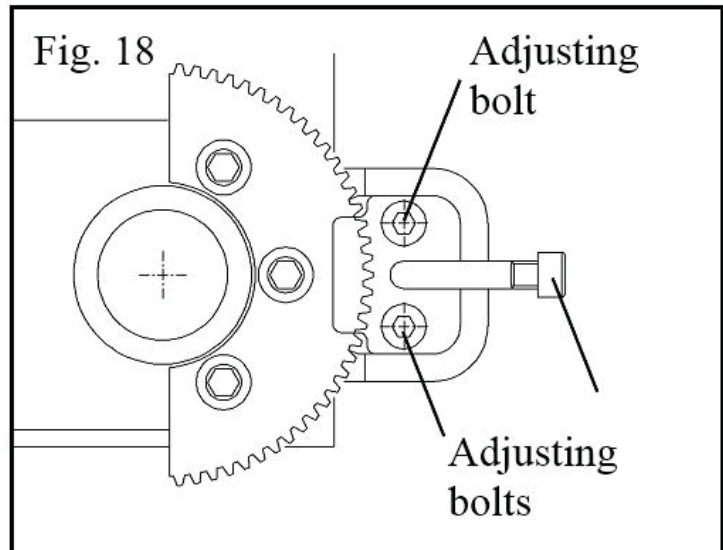
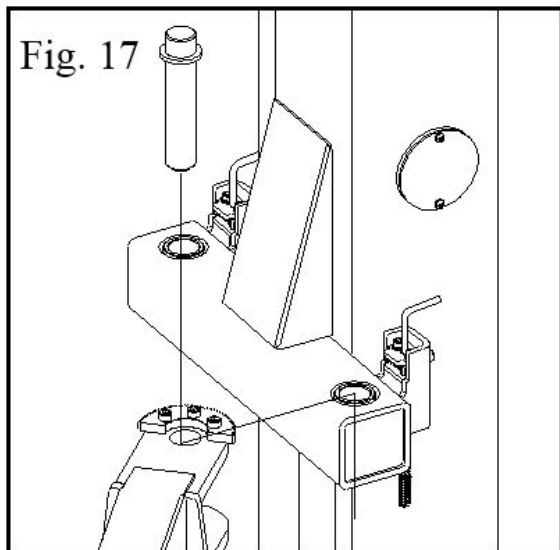

7.14 Check Before Start-Up

7.14.1 GENERAL CHECKS

- Make sure that the columns are plumb;
- Make sure the lift is anchored to the ground and all anchor bolts tightened.
- Make sure the electrical system feeding voltage is equal to that specified in the nameplate on the motor;
- Make sure the electric system connection is in conformity of the electric plan shown as the electric diagram (fig. 6) and for proper grounding.
- Particularly, below checks must be followed:

7.14.2 MECHANICAL SAFETIES FOR PROPER INSTALLATION

- Check to make sure that safety latches will properly engage and disengage by manual release;
- If latches click out of synchronization, tighten the cable on the one that clicks later.

7.14.3 EQUALIZER CABLE FOR PROPER INSTALLATION



The equalizer cables should be checked weekly for equal tension. Failure to do this will cause uneven lifting. The cables should always be adjusted so that they are equal tension when resting on the safety locks.

- Raise the carriages to check the equalizer cable tension by grasping the adjacent cables between the thumb and the forefinger so that you can just pull the cables together (ref. fig. 19);
- Adjust the cable tensions if necessary.

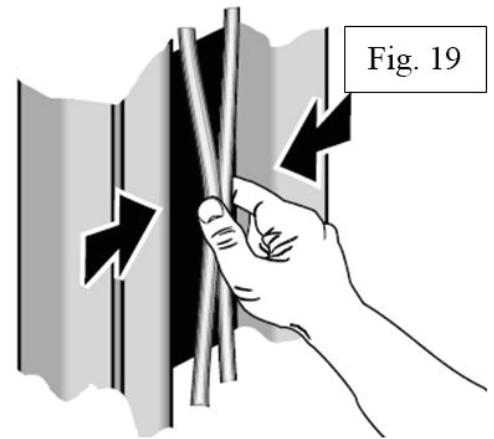

7.14.4 HYDRAULIC SYSTEM FOR PROPER OPERATION

- Make sure that the cylinder is located in the center hole in the base of column;
- Proper oil level in the tank, refill if needed;
- Raise the lift to the full height and keep the motor running for 5 seconds and check all hoses connections to make sure no leakage. Tighten the connections or reseal if necessary;
- Check the lift for reaching its maximum height;
- Repeat the air bleeding of cylinders if necessary.

7.15 Check With Load



WARNING: please follow carefully the instructions in the coming paragraph for avoiding damages on the lift.

Carried out two or three complete cycles of lowering with the vehicle loaded:

- Repeat the checks provided for by 7.14.
- Check no strange noise during lifting and lowering.

Operation And Use

	<p>NEVER operate the lift with any person or equipment below.</p> <p>NEVER exceed the rate lifting capacity.</p> <p>NEVER lift a vehicle in any manner with less than four arms.</p> <p>Always ensure that the mechanical locks are engaged before any attempt is made to work on or near the vehicle.</p> <p>Always lift a vehicle on the lifting pads.</p> <p>NEVER leave the lift in an elevated position unless the safeties are engaged.</p> <p>If an anchor bolt becomes loose or any component of the lift is found to be defective, DO NOT USE THE LIFT until repairs are made.</p>
---	--

8.1 Controls

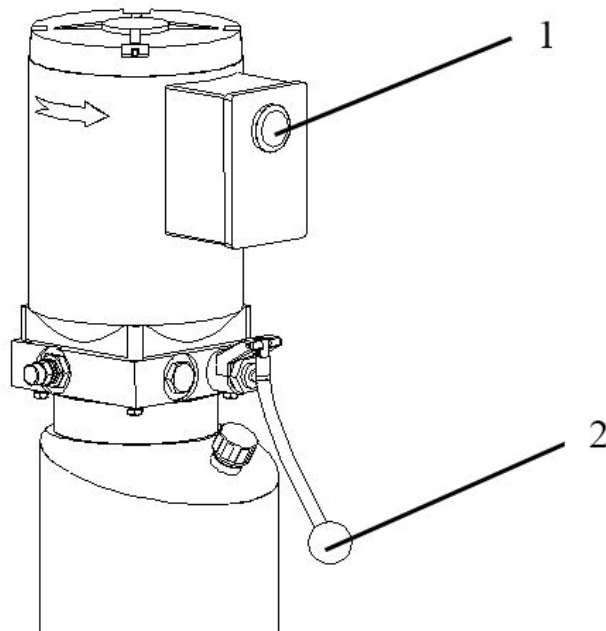

Figure 20 - Controls

Controls for operating the lift are:

LIFTING BUTTON (1)

- When pressed, the power unit is running and the lift can be raised to a desired height until the button is released.

LOWERING LEVER (2)

- If the mechanical locks are not released, the lift will lower to the nearest lock position.
- If both mechanical locks are released, press the lower lever, the lift will lower to the desired height under its weight and the load lifted until the lever is released.
- Locks will automatically reset once the lift ascends approximately 16" from base.

Lift operation can be summarized into four steps:

8.2 Vehicle Positioning

- Positioning the vehicle between columns;
- Adjust lift arms so that the vehicle is positioned with the center gravity between the pads. Make sure the arm safeties are engaged;
- Raise the lift by pressing the lifting button until the lifting adapters contact underside of the vehicle;
- Make sure the vehicle is secured.

8.3 Lifting

- Raise the lift by pushing the lifting button until reaching the desire height.

8.4 Standing

- Press the lowering lever to engage the nearest lock position;
- Always ensure that the lock in each column is engaged before any attempt is made to work on or near the vehicle.

8.5 Lowering

- Raise the lift a little bit by pushing the lifting button to clear off the mechanical locks;
- Release the locks manually;
- Lower the lift by pressing the lowering lever;
- Before removing vehicle from the lift area, position the lift arms to and pads to provide an obstructed exit;
- Never drive over the lift arms.

Maintenance



Only trained people who know how the lift works, can be allowed to service the lift.

To service properly the lift, the following has to be carried out:

- Use only genuine spare parts as well as equipment suitable for the work required;
- Follow the scheduled maintenance and check periods shown in the manual;
- Discover the reason for possible failures such as too much noise, overheating, oil blow-by, etc.
- Refer to documents supplied by the manufacture or dealer to carry out maintenance.



Before carrying out any maintenance or repair on the lift, disconnect the power supply.

9.1 Ordinary Maintenance

The lift has to be properly cleaned at least once a month using self-cleaning clothes.

Be sure the rod of the hydraulic cylinders is always clean and not damaged since this may result in leakage from seals and, as a consequence, in possible malfunctions.



The use of water or inflammable liquid is strictly forbidden

9.2 Periodic Maintenance

Daily pre-operation	<ul style="list-style-type: none">• Check hydraulic connections and hoses for leaks• Check mechanical locks audibly and visually while in operation• Check arm locks• Check bolts, nuts and screws are tight
Every 1 month	<ul style="list-style-type: none">• Check all cable connections, pins and bolts to insure proper mounting• Inspect all anchor bolts and retighten if necessary• Check columns for squareness and plumb• Check equalizer cable tension, adjust if necessary• Check safety cable, adjust it if necessary• Check all arm pivot pins. Make sure they are properly secured• Check all lifting pads, replace if necessary• Lubricant columns with grease• Check the hydraulic oil, fill or replace if necessary• Check hydraulic systems for proper operation
Every 12 months	<ul style="list-style-type: none">• Verify that all components and mechanisms are not damaged• Verify the equalizer cables are not worn, change if necessary• Check the electrical system to verify that the motors operate properly (this work must be carried out by skilled electricians)• Empty the oil tank and change the hydraulic oil

Troubleshooting

A list of possible troubles and solutions is given below:

Trouble:	Possible Cause:	Solution:
The lift does not work	There is no power	Check Power on to restore if necessary
	The electrical wires are disconnected	Reconnect
	The circuit breaker are blown	Check for correct voltage Replace
The lift does not raise	The lift is overloaded	Check the vehicle weight
	The motor direction of rotation is not correct.	Interchange the two phases on the main switch
	The oil in the power unit is not sufficient.	Add some hydraulic oil
	The UP button is faulty.	Check UP button and connection for proper operation. Replace if needed
	The lowering valve does not close.	Check and clean, if dirty or replace if faulty
	The suction tube or pump filter is dirty.	Check and clean if needed.
	Presence of air in the hydraulic system	Bleed the hydraulic system
The lifting capacity is not sufficient	The pump is faulty	Check the pump and replace if needed.
	Oil leakages in hydraulic circuit	Check the circuit for any leakage
The lift does not lower when the lowering lever and the safety release lever are pressed	The lowering valve does not work properly	Check the valve and replace if needed.
	The safety release cables are not in the same tension.	Readjust the cable.
The lift does not lower smoothly	Presence of air in the hydraulic system	Bleed the hydraulic system
	Lubrication of sliders is not enough.	Grease
	Sliders are damaged	Replace

* If the problems remain unsolved, call for technical support.

Parts List

Lift

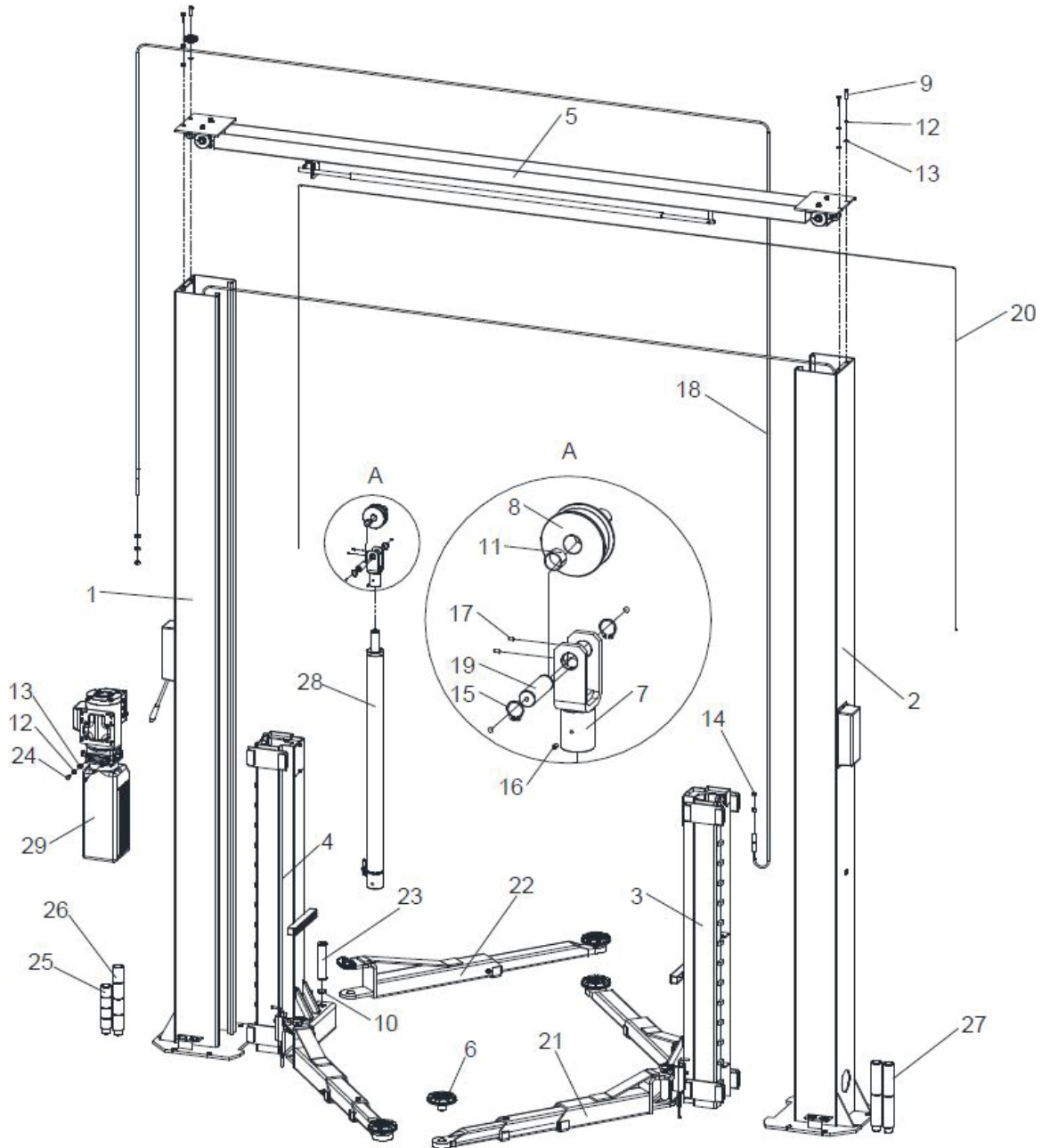

ITEM	PART NO.	DESCRIPTION	QTY
1	Z31B110000	Power-side column	1
2	Z31B120000	Off-side column	1
3	Z31B220000	Slave carriage assembly	1

ITEM	PART NO.	DESCRIPTION	QTY
4	Z31B210000	Main carriage assembly	1
5	Z31A400000	Overhead beam assembly	1
6	Z31B330000	Lifting adapter	4
7	Z31A600100	Pulley base	2
8	Z31A600002	Pulley	2
9	0201050	Screw M10X35 - GB/T5783	4
10	0212023	Seeger D.38	4
11	0210008	Self-lubricated bush 2520	4
12	0208007	Locking washer D.10 - GB/T93	6
13	0205011	Washer D.10 - GB/T97.1	6
14	0203023	Nut M12 - GB/T6170	10
15	0212004	Seeger D.25 - GB/T894.1	4
16	0209037	Screw M6X10 - GB/T80	2
17	0209017	Screw M4X8 - GB/T80	4
18	Z31B500000	Equalizer steel cable	2
19	XSZ-7-11Y	Pulley shaft	2
20	Z31A510000	Safety release wire	1
21	Z31B310000	Short arm assembly	2
22	Z31B320000	Long arm assembly	2
23	Z31B000100	Arm shaft	4
24	0201062	Screw M10X20 - GB/T5783	2
25	XSZ-7-5-1	Adapter extension H.50	4
26	XSZ-7-5-2	Adapter extension H.75	4
27	XSZ-7-5-3	Adapter extension H.150	4
28	Z31AY63000	Hydraulic cylinder	2
29	0302014	Hydraulic power unit	1

Power-Side Column

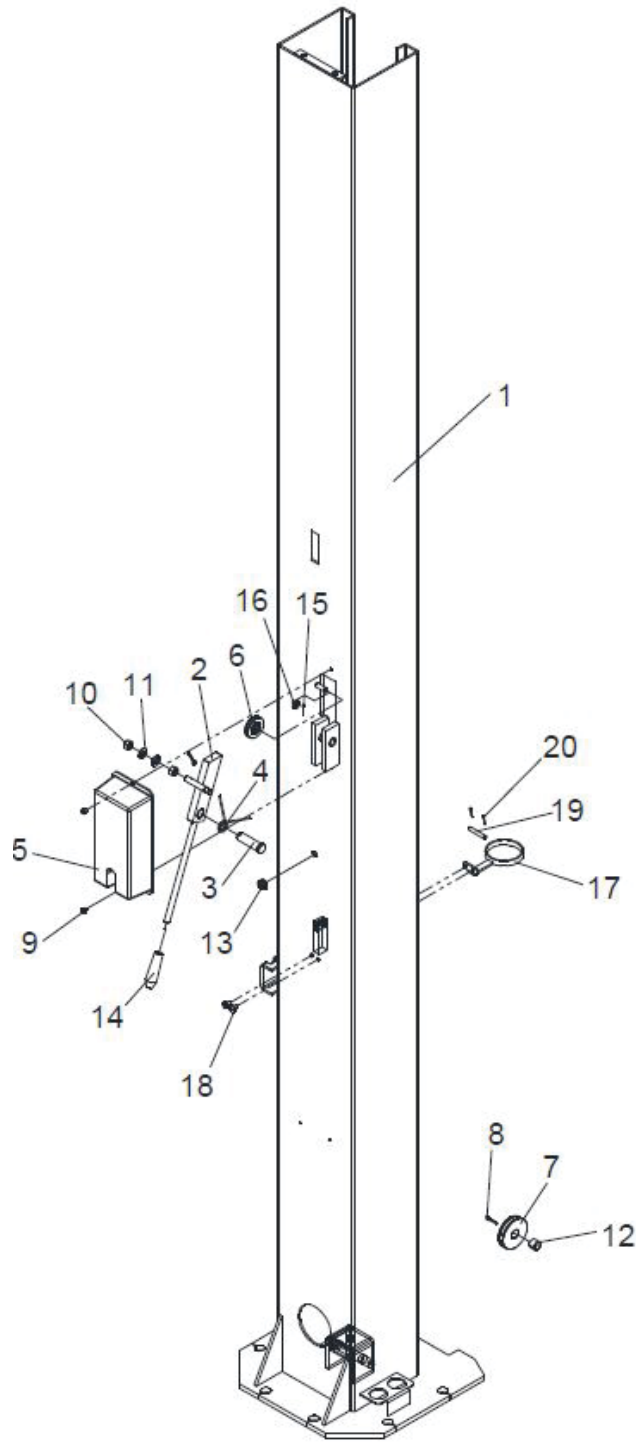

ITEM	PART NO.	DESCRIPTION	QTY
1	Z31B111000	Main Column	1
2	Z31A112000	Safety rack	1
3	Z31A110001	Shaft	1
4	Z31A110002	Spring	1

ITEM	PART NO.	DESCRIPTION	QTY
5	Z31A110003	ABS cover with hole	1
6	Z31A110004	Roller	1
7	Z31A110005	Lower pulley	1
8	0213035	Pin 4X30	2
9	0206036	Screw M6X8 - GB/T818	2
10	0203023	Nut M12 - GB/T6170	2
11	0205013	Washer D.12 - GB/T97.1	2
12	0210112	Bush SF-1	1
13	0606024	Cable relief	1
14	0606216	Handle cover	1
15	0213044	Split pin 2X20	1
16	0205011	Washer D.10 - GB/T97.1	1
17	Z31A111200	Support	1
18	0206001	Screw M8X12 - GB/T818	2
19	XSZ-7-12	Chain pin	1
20	0213044	Split pin 2X20 - GB/T91	1

Off-Side Column

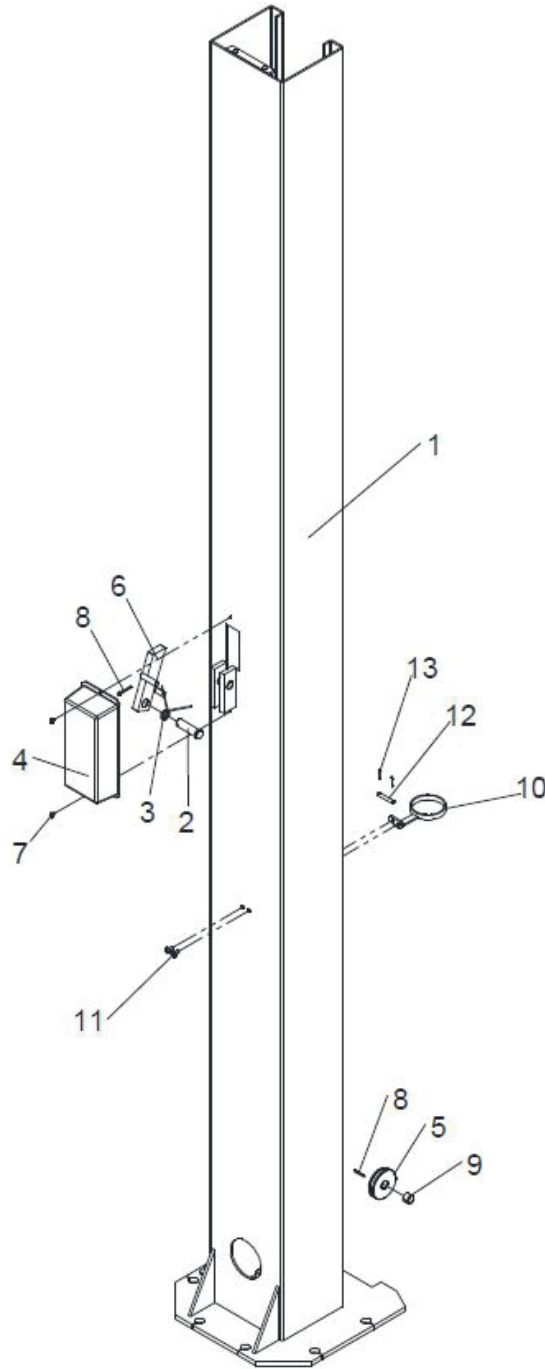

ITEM	PART NO.	DESCRIPTION	QTY
1	Z31B121000	Slave Column	1
2	Z31A110001	Shaft	1
3	Z31A110002	Spring	1
4	Z31A110003A	ABS cover	1
5	Z31A110005	Lower pulley	1

ITEM	PART NO.	DESCRIPTION	QTY
6	Z31A122000	Safety rack	1
7	0206036	Screw M6X8 - GB/T818	2
8	0213035	Pin 4X30	2
9	0210112	Bush SF-1	1
10	Z31A111200	Support	1
11	0206001	Screw M8X12 - GB/T818	2
12	XSZ-7-12	Chain pin	1
13	0213044	Split pin 2X20 - GB/T91	2

Carriage

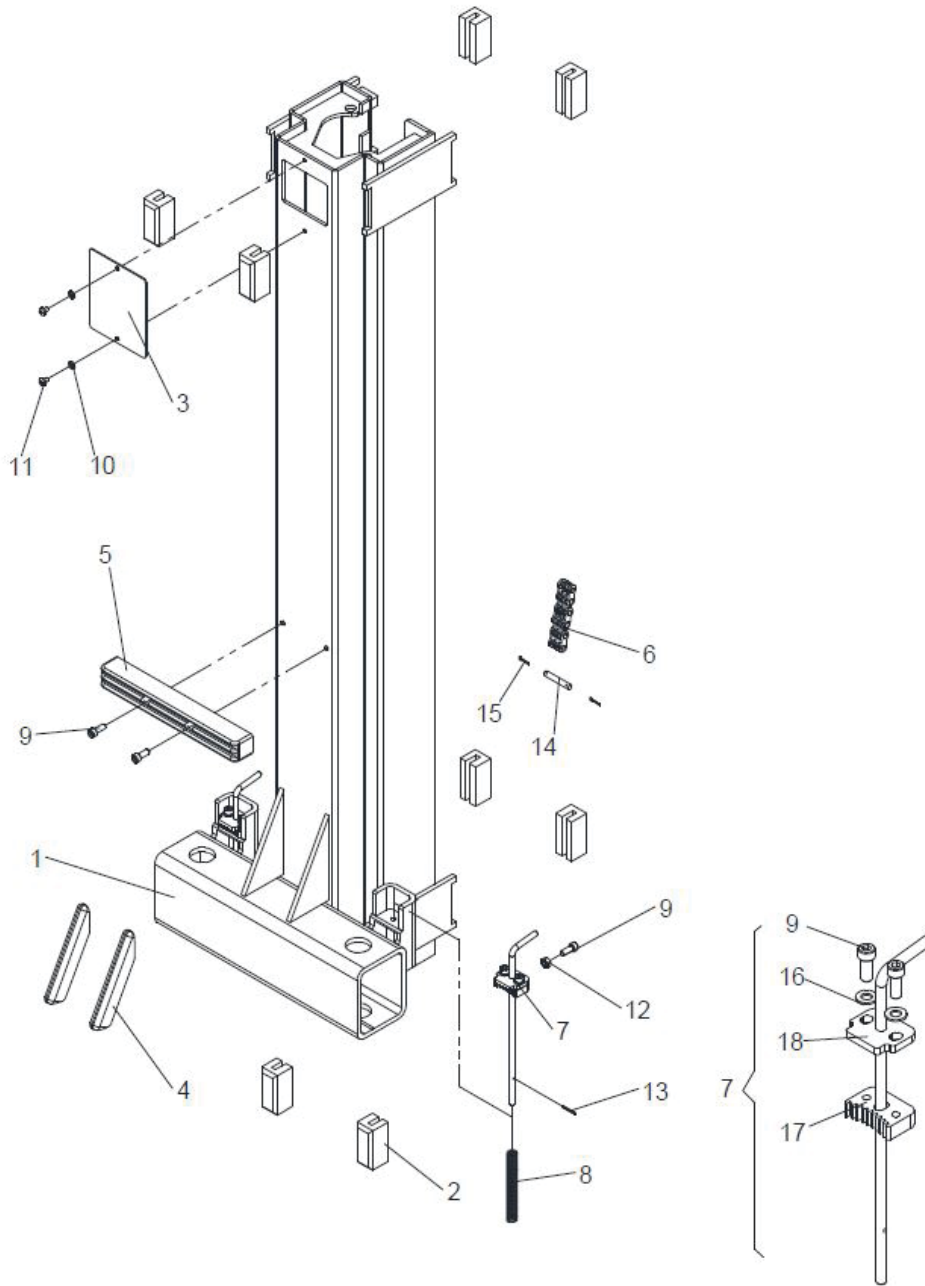

ITEM	PART NO.	DESCRIPTION	QTY
1a	Z31B211000	Carriage (For Main carriage assembly)	1
1b	Z31B221000	Carriage (For Slave carriage assembly)	1
2	Z31A210001	Slider	8
3	Z31A210002	Cover	1
4	Z31A210003	Protection cover	2
5	Z23B711001	Rubber pad	1
6	0215125	Chain BL634X73	1

ITEM	PART NO.	DESCRIPTION	QTY
7	XSZ-6-00Y	Arm safety	2
8	XSZ-6-5	Spring	2
9	0202045	Screw M8X20 - GB/T70.1	4
10	0205006	Washer D.6 - GB/T97.1	2
11	0206036	Screw M6X8 - GB/T818	2
12	0203029	Nut M8 - GB/T6170	2
13	0213002	Elastic pin 3X26 - GB/T879.1	2
14	XSZ-7-12	Chain pin	1
15	0213044	Split pin 2X20 - GB/T91	2
16	0205008	Washer D.8 - GB/T97.1	2
17	XSZ-6-7TY	Toothed plate	1
18	XSZ-6-4Y	Release pin	1

Overhead Beam

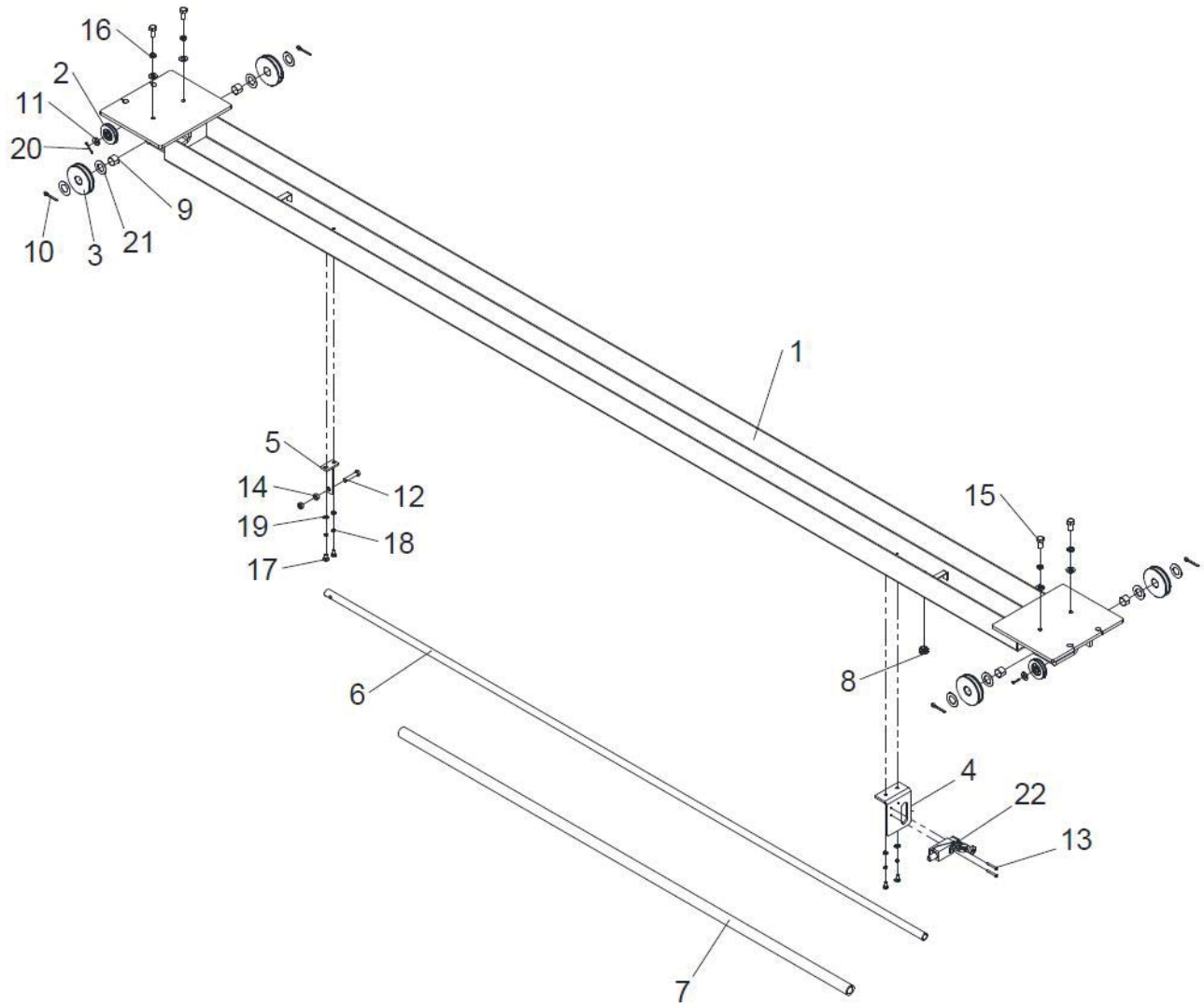

ITEM	PART NO.	DESCRIPTION	QTY
1	Z31A410000	Overhead beam	1
2	Z31A110004	Roller	2
3	Z31A110005	Lower pulley	4
4	2L-1-07	Safety bar support	1
5	SYJ30-17-02M1	Bar bracket	1
6	SYJ30-17-06M	Crush safety bar	1
7	SYJ30-17-07M	Crush safety bar cover	1
8	0606024	Cable holder D.16	1
9	0210112	Bush SF-1	4
10	0213035	Pin 4X30	4

ITEM	PART NO.	DESCRIPTION	QTY
11	0205011	Washer D.10 - GB/T97.1	6
12	0201037	Screw M8X40 - GB/T5783	1
13	0206018	Screw M4X30 - GB/T818	2
14	0203029	Nut M8 - GB/T6170	2
15	0201062	Screw M10X20 - GB/T5783	4
16	0208007	Locking washer D.10 - GB/T93	4
17	0206040	Screw M6X12 - GB/T818	4
18	0208005	Spring washer D.6 - GB/T93	4
19	0205006	Washer D.6 - GB/T97.1	4
20	0213044	Pin 2X20	2
21	Z31A400002	Adjust washer	8
22	0505018	Top limit switch 8108	1

Arm And Adapter

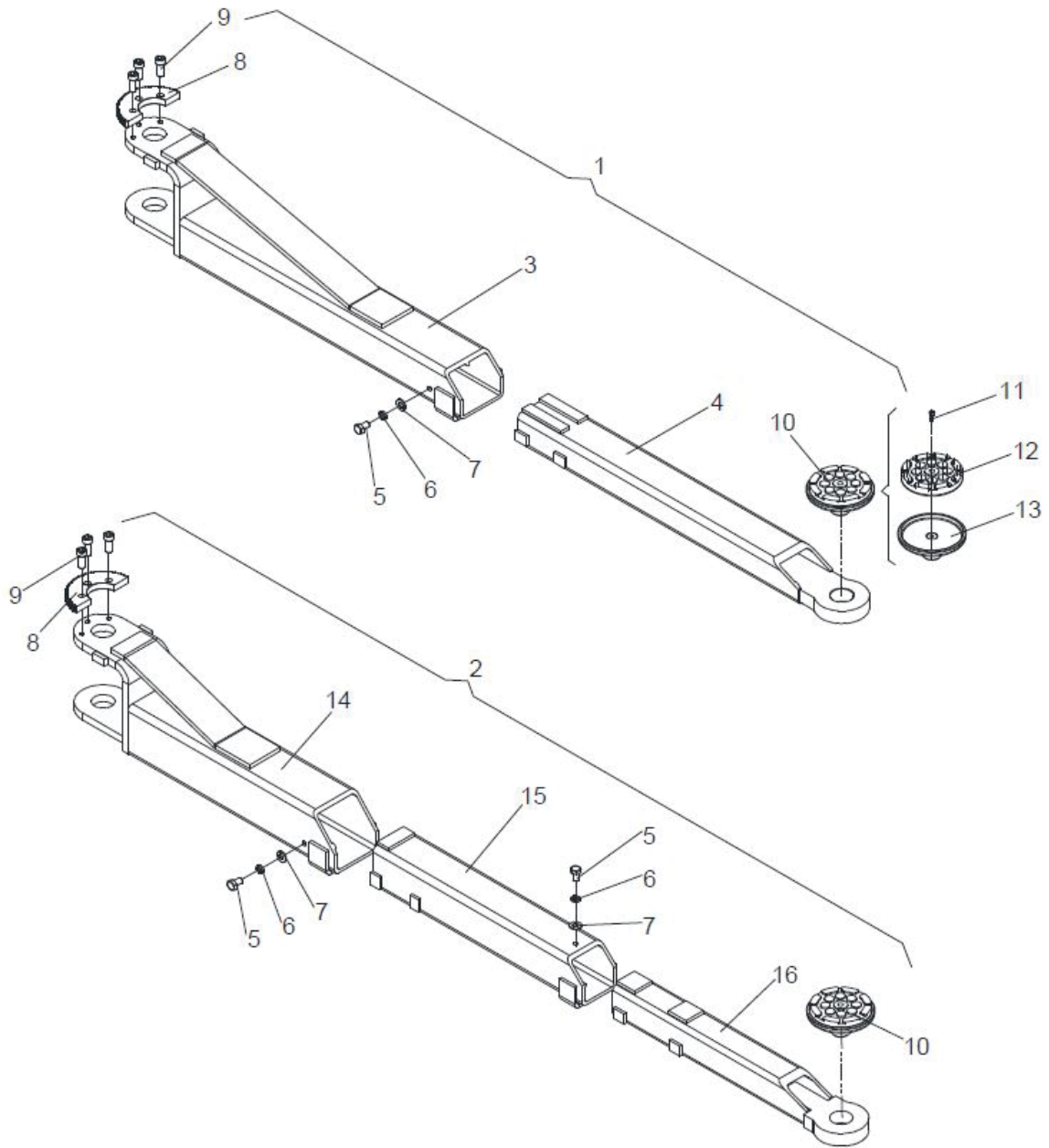

ITEM	PART NO.	DESCRIPTION	QTY
1	Z31B320000	Long arm assembly	1
2	Z31B310000	Short arm assembly	1
3	Z31B321000	Long arm frame	1
4	Z31B322000	Long arm outer extension	1
5	0201059	Screw M10X16 - GB/T5783	3
6	0208007	Locking washer D.10 - GB/T93	3
7	0205011	Washer D.10 - GB/T97.1	3

ITEM	PART NO.	DESCRIPTION	QTY
8	XSZ-3-1TY	Anti-rotating gear	2
9	0202120	Screw M10X25 - GB/T70.1	6
10	Z31B330000	Lifting adapter	2
11	0202032	Screw M6X16 - GB/T70.1	1
12	Z31B330001	Round rubber pad	1
13	Z31A321000	Pad support	1
14	Z31B311000	Short arm frame	1
15	Z31B312000	Short arm middle extension	1
16	Z31B313000	Short arm outer extension	1

Hydraulic Line

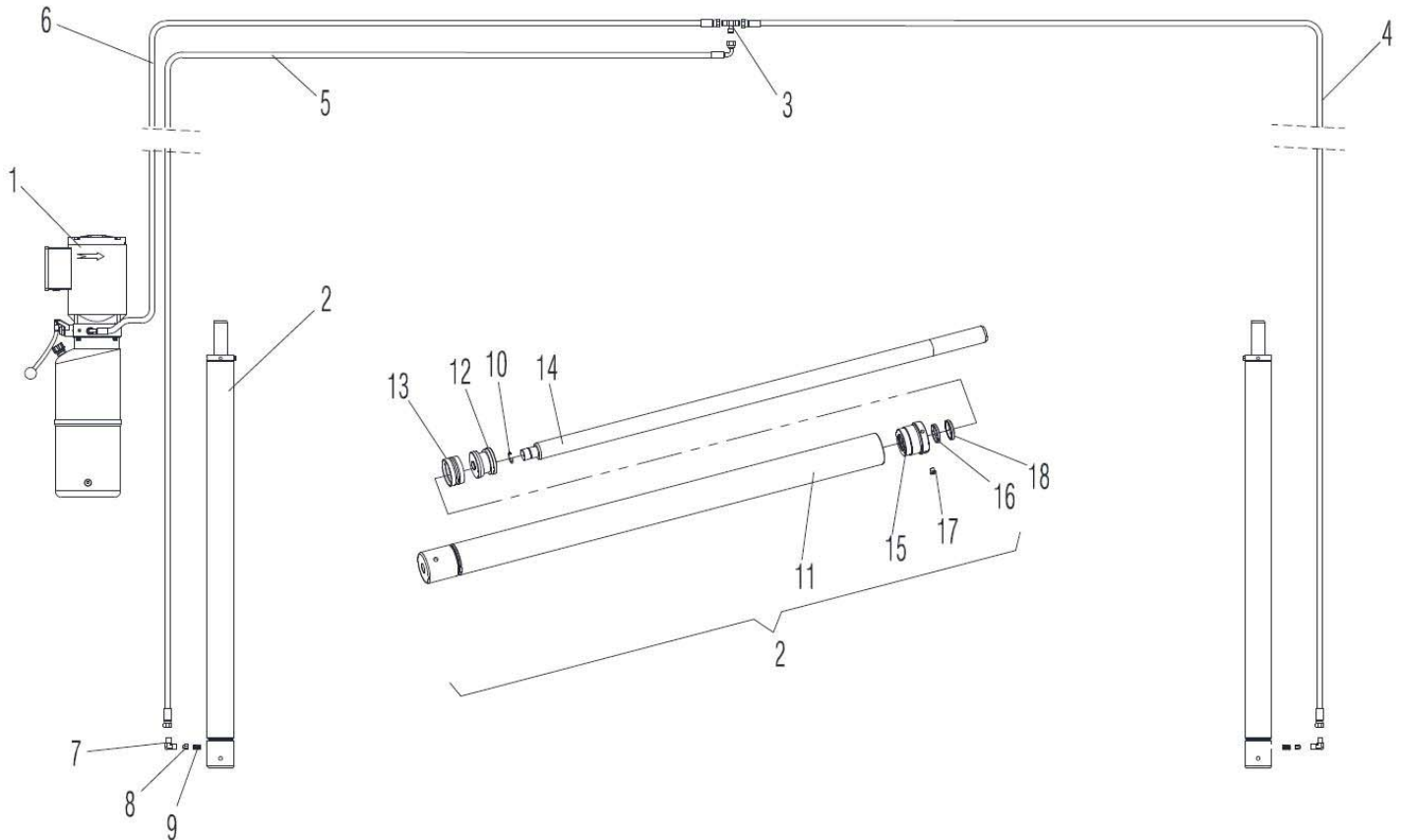

ITEM	PART NO.	DESCRIPTION	QTY
1	0302014	Hydraulic power unit	1
2	Z31AY63000	Hydraulic cylinder	2
3	0303021	Tee union 1/4	1
4	ZZ4850	Hydraulic pipe L=4850	1
5	ZW4900	Hydraulic pipe L=4900	1
6	ZW4300	Hydraulic pipe L=4300	1
7	0303002	90° union 1/4 (1BT9-04SP)	2
8	6432-Y1.5	Flow restrictor	2
9	7530-Y-3	Spring	2
10	0211032	Seeger D.25	1
11	Z31AY63100	Cylinder liner	1
12	Z31AY63001	Piston	1
13	0312012	Gasket 63X47X18.4	1
14	Z31AY63004	Piston rod	1

ITEM	PART NO.	DESCRIPTION	QTY
15	SYJ-30-63-6	Cylinder guiding cover	1
16	0305005	Guiding ring 38X5.6X2.5	1
17	0306087	Silencer 1/8	1
18	0311007	Scraper 38X46X5/6.5	1

Warranty



This item is warranted for five (5) years on structural components, two (2) years on hydraulic cylinders, and one (1) year on electric or air / hydraulic power units from invoice date. Wear items are covered by a 90 day warranty.

This LIMITED warranty policy does **not include a labor** warranty.

NOTE: ALL WARRANTY CLAIMS MUST BE PRE-APPROVED BY THE MANUFACTURER TO BE VALID.

The Manufacturer shall repair or replace at their option for this period those parts returned to the factory freight prepaid, which prove after inspection to be defective. This warranty will not apply unless the product is installed, used and maintained in accordance with the Manufacturers installation, operation and maintenance instructions.

This warranty applies to the ORIGINAL purchaser only, and is non-transferable. The warranty covers the products to be free of defects in material and workmanship but, does not cover normal maintenance or adjustments, damage or malfunction caused by: improper handling, installation, abuse, misuse, negligence, carelessness of operation or normal wear and tear. In addition, this warranty does not cover equipment when repairs or alterations have been made or attempted to the Manufacturer's products.

THIS WARRANTY IS EXCLUSIVE AND IS LIEU OF ALL OTHER WARRANTIES EXPRESSED OR IMPLIED INCLUDING ANY IMPLIED WARRANTY OR MERCHANTABILITY OR ANY IMPLIED WARRANTY OF FITNESS FROM A PARTICULAR PURPOSE, AND ALL SUCH IMPLIED WARRANTIES ARE EXPRESSLY EXCLUDED.

THE REMEDIES DESCRIBED ARE EXCLUSIVE AND IN NO EVENT SHALL THE MANUFACTURER, NOR ANY SALES AGENT OR OTHER COMPANY AFFILIATED WITH IT OR THEM, BE LIABLE FOR SPECIAL CONSEQUENTIAL OR INCIDENTAL DAMAGES FOR THE BREACH OF OR DELAY IN PERFORMANCE OF THIS WARRANTY. THIS INCLUDES, BUT IS NOT LIMITED TO, LOSS OF PROFIT, RENTAL OR SUBSTITUTE EQUIPMENT OR OTHER COMMERCIAL LOSS.

PRICES: Prices and specifications are subject to change without notice. All orders will be invoiced at prices prevailing at time of shipment. Prices do not include any local, state or federal taxes.

RETURNS: Products may not be returned without prior written approval from the Manufacturer.

DUE TO THE COMPETITIVENESS OF THE SELLING PRICE OF THESE LIFTS, THIS WARRANTY POLICY WILL BE STRICTLY ADMINISTERED AND ADHERED TO.