

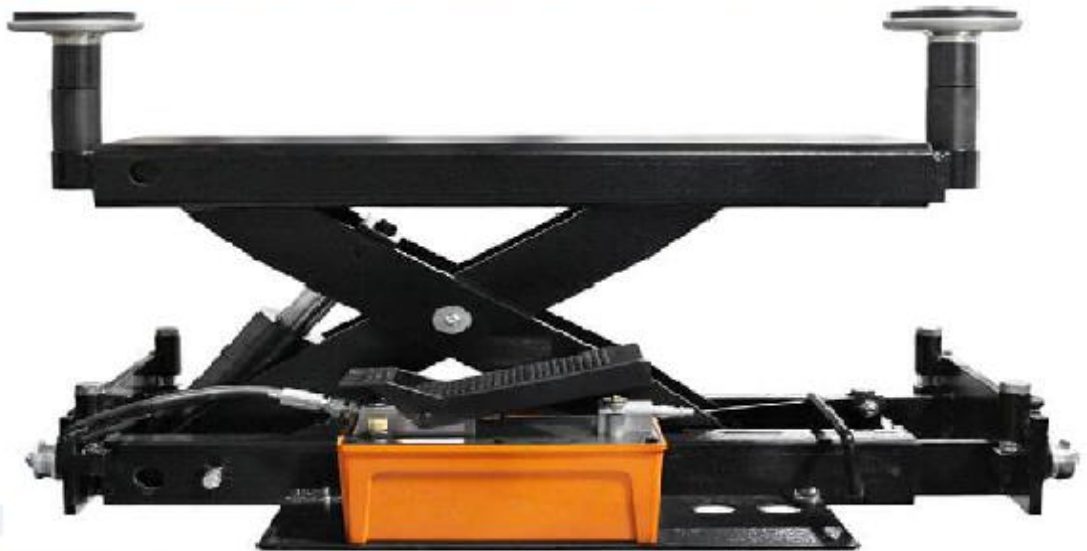

Atlas RJ6

**6,000 lb. Capacity
Center Rolling Jack**



Atlas Automotive Equipment
www.atlasautoequipment.com
(866) 898-2604

CONTENTS

1	GENERAL INFORMATION	3
2	PRODUCT DESCRIPTION	4
3	INSTALLATION	7
4	OPERATION	8
5	MAINTENANCE	10
6	TROUBLESHOOTING	11

CHAPTER 1 – GENERAL INFORMATION

!CAUTION!

Before using this product, read and fully understand this manual.

Read every section of this manual carefully before operating the rolling jack, following the guidelines provided within this document will prevent damage and injury during operation.

The manufacturer/supplier is not liable for possible problems, damage, accidents, etc. resulting from improper use of this rolling bridge jack and/or failure to follow the instructions contained in this manual.

Only skilled technicians should be allowed to operate, assemble or install, adjust or calibrate, provide maintenance to or repair, and overhaul or dismantle this bridge jack.

For future reference it is recommended to:

- keep the manual in an easily accessible place near the jack during use.
- keep the manual in a waterproof secure location.

This manual is an integral part of the rolling bridge jack and should be transferred with the bridge jack if moved or sold.

This rolling jack should **NEVER BE USED** by an operator under the influence of sedatives, drugs or alcohol.

DECLARATION OF WARRANTY AND LIMITATION OF LIABILITY

The manufacturer has paid proper attention to the preparation of this manual. However, nothing contained herein modifies or alters, in any way, the terms and conditions of manufacturer agreement by which this rolling bridge jack was acquired, nor increase, in any way, manufacturer's liability to the customer.

TO THE READER

Every effort has been made to ensure that the information contained in this manual is correct, complete, and up-to date. The manufacturer is not liable for any mistakes made when drawing up this manual and reserves the right to make any changes due to the development of the product, at any time.

CHAPTER 2 - DESCRIPTION

2.1 DESCRIPTION (Ref. Figure 1)

This air/hydraulic rolling jack has been designed to be placed on a lift for maintenance of vehicles.

This chapter describes the unit's principal elements, allowing the user to be familiar with the rolling jack.

As shown in figure 1, the bridge jack is composed of the base unit (1) and an air-hydraulic pedal pump (2) which can be placed on the holder (3).

Raising or lowering of the jack is carried out by operating the pump as shown in chapter 4.

Figure 1

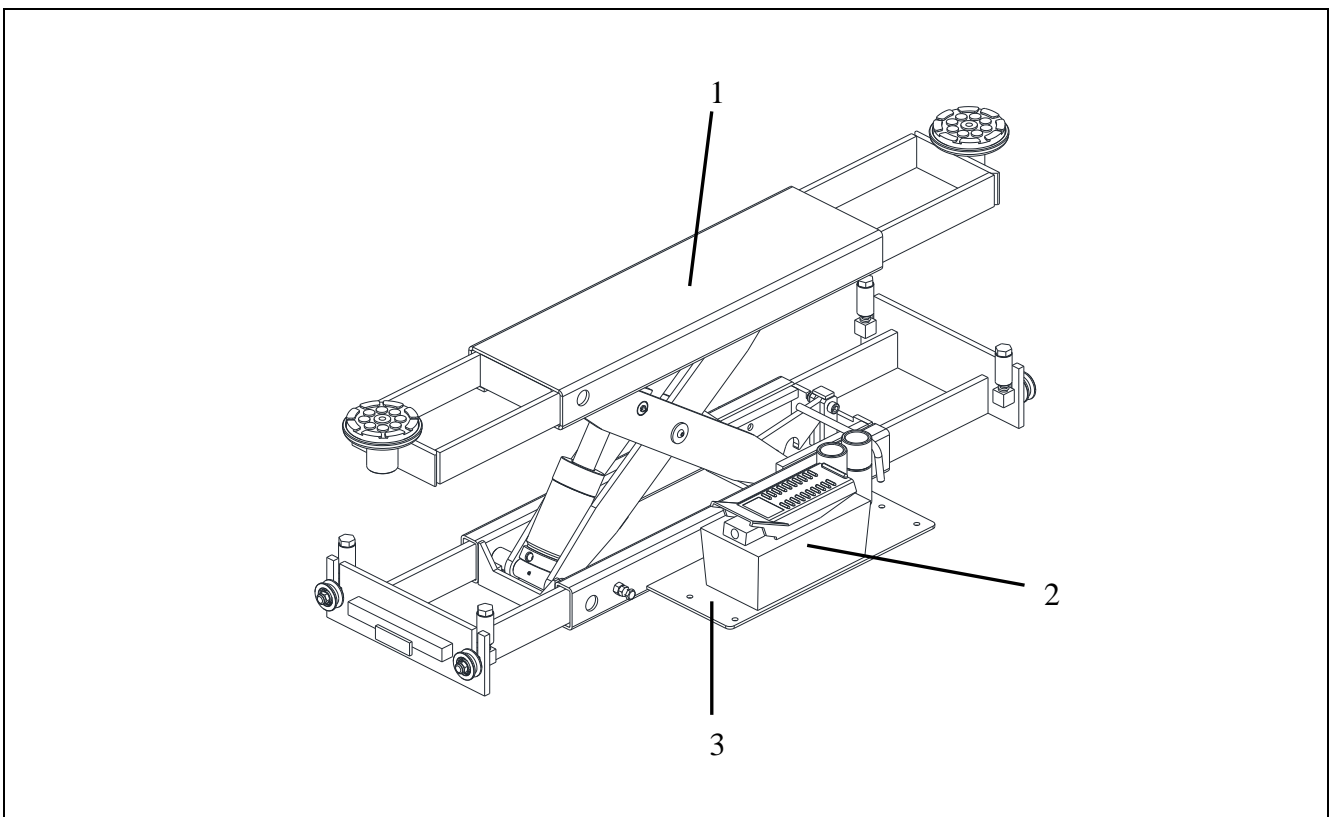

2.2 MAIN FEATURES

Capacity	6,000 lbs (2700 Kgs)
Max. lifting height with no pad extensions	19 in.
Min. lowered height	9.25 in.
Lifting points adjusted (Center to Center)	33 – 54 in.
Base adjustable	32 – 50 in.
Lifting time	20 s
Noise level	70 dB(A)/1m
Working temperature	15 °F - 100 °F
Average weight of the package	331 lbs.

2.3 PUMP

Type	Air-hydraulic
Compressed air pressure	70 PSI – 115 PSI
Max. working hydraulic pressure	5000 PSI (350 Bar)
Volume of oil reservoir	800cc

2.4 LAYOUT (Figure 2)

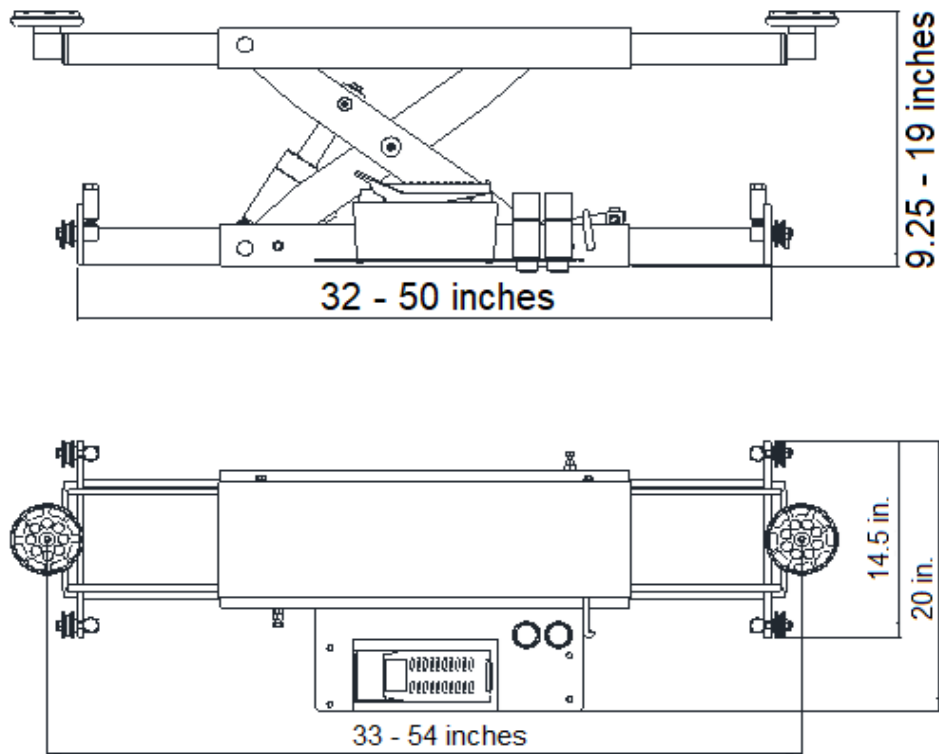

2.5 HYDRAULIC PLAN (Figure 2)

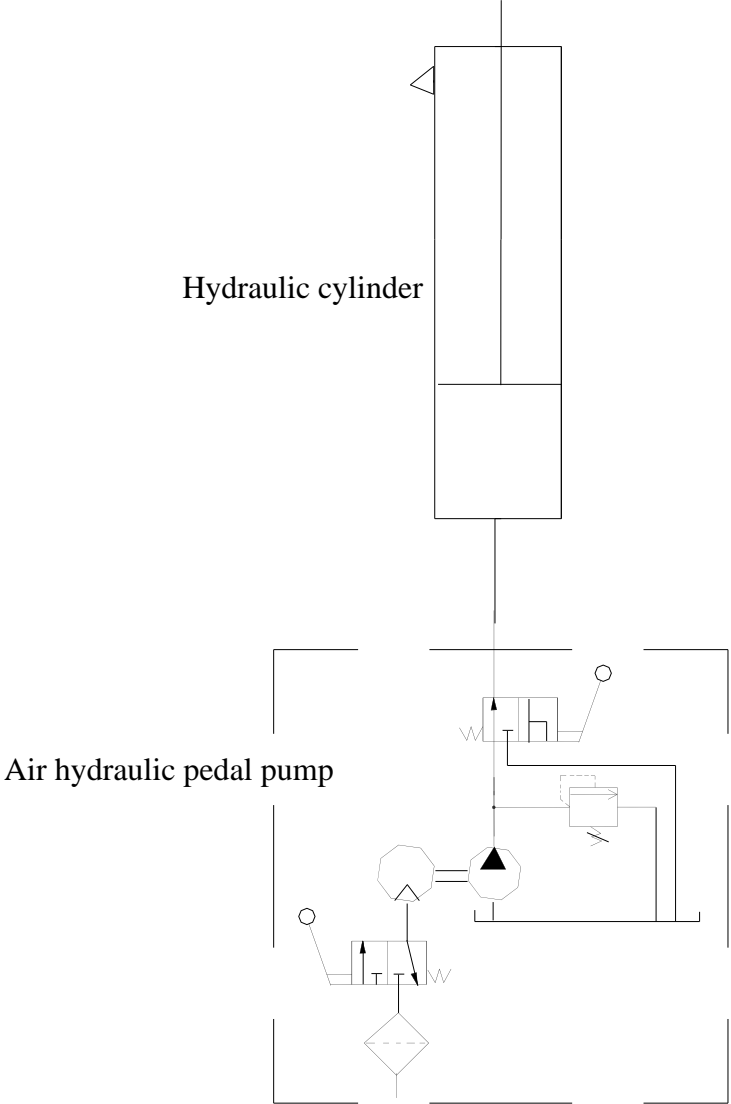

CHAPTER 3 – INSTALLATION

3.1 HYDRAULIC LINE CONNECTION (ref. figure 3)

- Connect hydraulic hose to the fittings;
- Tighten thoroughly;
- Connect the air-hydraulic pump to an external air supply (not included with jack);
- Check the pneumatic control operations for proper performance.

 **For extended service and proper operation, it is recommended that external air supply include a water separator, lubricator and pressure reducer.**

Figure 3 – LINE CONNECTION



CHAPTER 4 - OPERATION

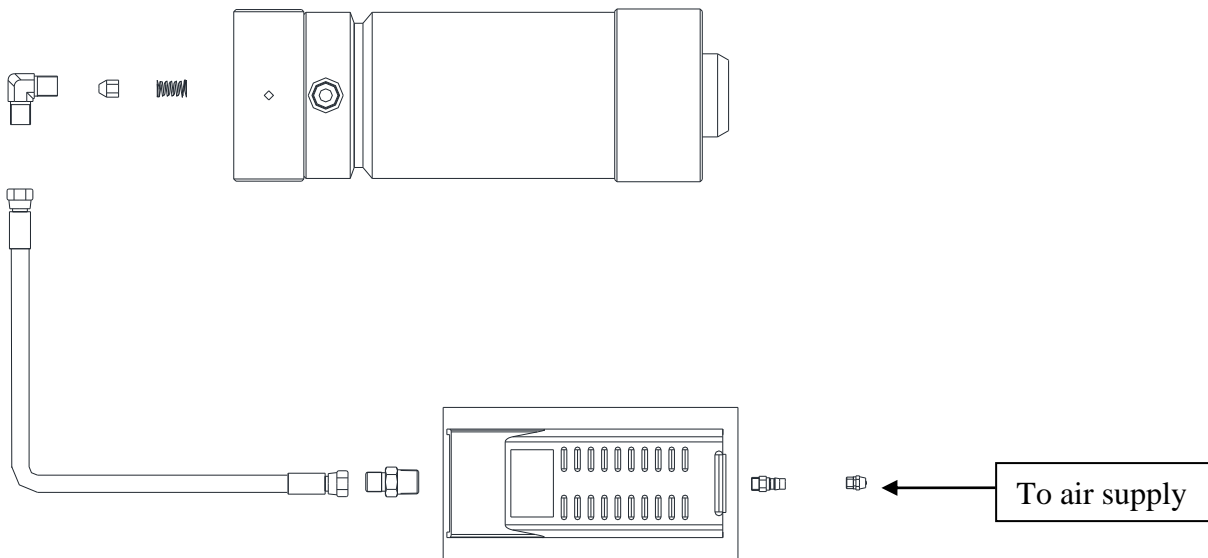

Never operate the lift except for intended purpose.
Never exceed the rated lifting capacity.
Never raise the jack more than the rated height.

4.1 CONTROLS

Controls for operating the jack are:

Figure 4 – CONTROLS OF BRIDGE JACK

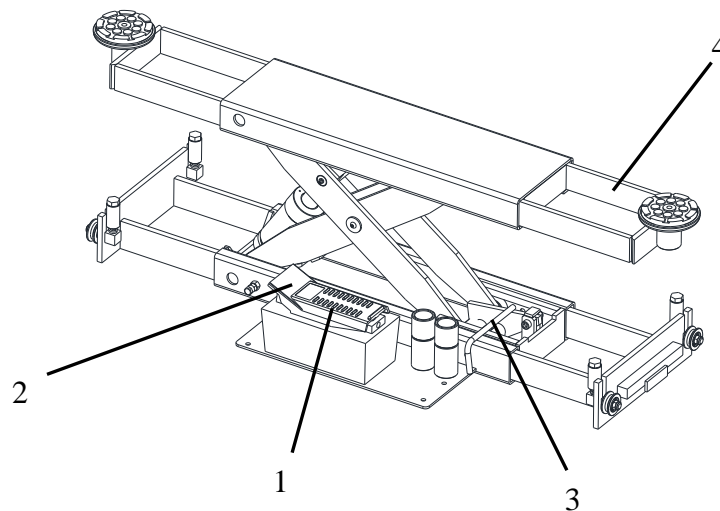

LIFTING SIDE OF PEDAL (1)

- When pressed, the hydraulic fluid is delivered from the oil reservoir of the pump into the jack cylinder to raise the jack.

LOWERING SIDE OF PEDAL (2)

- When pressed, the hydraulic fluid is released from the jack cylinder into the oil reservoir of the pump to lower the jack under the weight loaded. The lowering speed can be controlled by the pressing force.

SAFETY LOCK RELEASE HANDLE (3)

- Flip the safety lock release handle up off the safety to lower.



Always ensure that the mechanical safety is engaged before any attempt is made to work on or near the vehicle.

JACK LIFTING ARM (4)

Jack operation can be summarized in three steps:

4.2 LIFTING



Never raise the jack beam beyond rated height. The manufacturer will not be responsible for the damage because of the incorrect operation.

- Check and keep the lift rail channel clean of debris and any object that may hinder the movement of the bridge jack.
- Lower the jack fully by depressing the lowering side of the pedal.
- Adjust the width of the jack lifting arms so that the rubber pads will contact the lifting points of the vehicle recommended by the vehicle manufacturer.
- Raise the jack by depressing the lifting side of the pedal. Keep an eye on the jack when the rubber pads contact the vehicle to ensure proper contact. Re-adjust the width of the jack lifting arms if necessary.

4.3 STANDING

- Stop raising the jack just as vehicle is raised off the lift runways. Confirm the vehicle is stable and seated properly before lifting the vehicle to the desired height.
- After the vehicle is raised to the desired height, lower the jack to the nearest safety lock position.

4.4 LOWERING

- Be sure the safety area is free of people and obstructions.
- Raise the jack high enough to clear off the mechanical safety lock and then flip the safety release handle up off the lock.
- Lower the jack fully by continuing to press the lowering side of the pedal.

CHAPTER 5 - MAINTENANCE

	Only trained personnel who know how the jack works, should be allowed to service the jack.
---	---

To properly service the lifting jack, the following should be carried out:

- use only genuine spare parts as well as equipment suitable for the work required;
- follow the scheduled maintenance and check periods shown in the manual;
- discover the reason for possible failures such as too much noise, overheating, oil blow-by, etc.

Refer to documents supplied by the dealer to carry out maintenance:

- functional drawing of the electric and hydraulic equipment
- exploded views with all data necessary for spare parts ordering
- list of possible faults and relevant solutions.

5.1 ORDINARY MAINTENANCE

The jack must be properly cleaned at least once a month. Use self-cleaning clothes.

	The use of water or inflammable liquid is strictly forbidden
--	---

Be sure the rod of the hydraulic cylinder is always clean and not damaged since this may result in leakage from seals and possible malfunctions.

5.2 PERIODIC MAINTENANCE

Every 3 months	Hydraulic system	<ul style="list-style-type: none">▪ check oil level in the pump reservoir; refill with oil, if needed;▪ check the system for oil leakage.
Every 6 months	Oil	<ul style="list-style-type: none">▪ Check oil for contamination or ageing. Contaminated oil is the main reason for failure of valves and shorter life of the pump
Every 12 months	General check	<ul style="list-style-type: none">▪ verify that all components and mechanisms are not damaged

CHAPTER 6 - TROUBLESHOOTING

A list of possible troubles and solutions is given below:

TROUBLE:	POSSIBLE CAUSE:	SOLUTION:
The jack does not raise	The oil in the pump reservoir is not sufficient.	Add hydraulic oil
	The pump is faulty	Check and replace if necessary.
The lifting capacity is not sufficient	The hydraulic pump is faulty	Check the pump and replace, if needed
The jack does not lower	The pump is faulty	Check and replace if necessary.
The jack does not lower smoothly	Air in the hydraulic system	Bleed the hydraulic system